

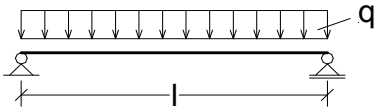
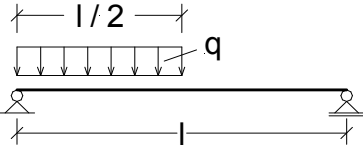
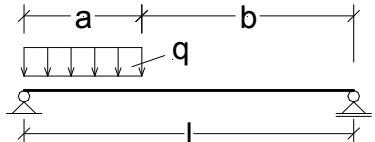
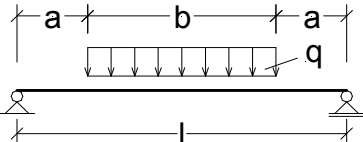
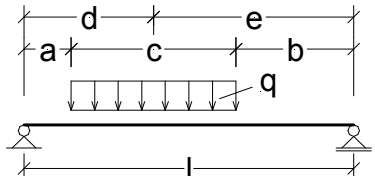
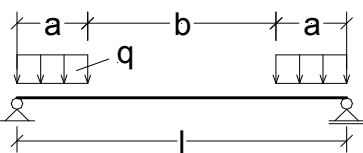
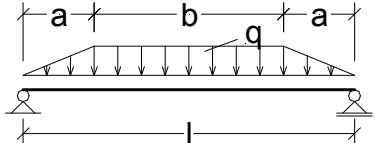
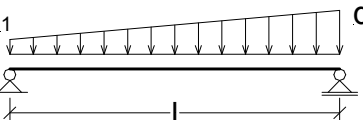
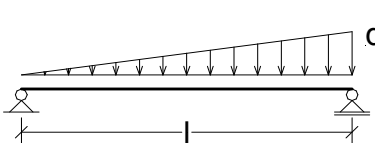
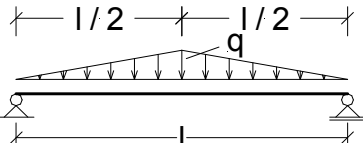
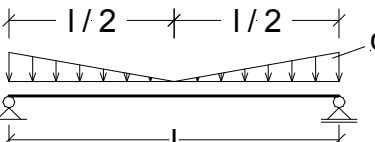
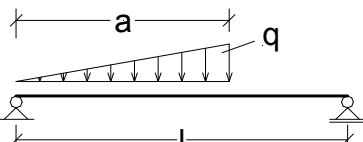
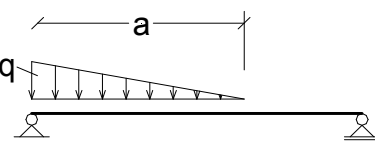
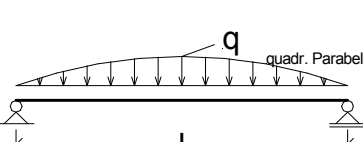
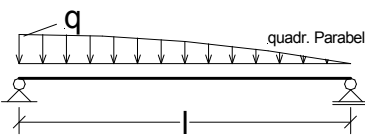
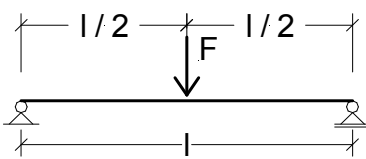
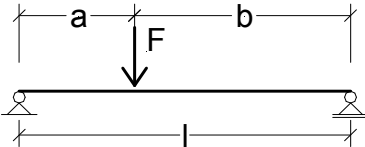
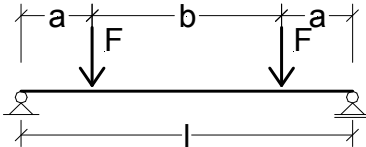
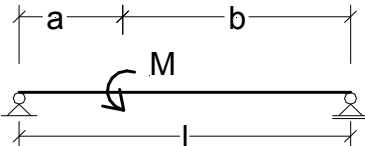

## Templates structural formulae

Simple beam

	
<p>Load</p>	<p>Load</p>
	
<p>Load</p>	<p>Load</p>
	
<p>Load</p>	<p>Load</p>
	
<p>Load</p>	<p>Load</p>
	
<p>Load</p>	<p>Load</p>
	
<p>Load</p>	<p>Load</p>
	
<p>Load</p>	<p>Load</p>

	
<p>Load</p>	<p>Load</p>
	
<p>Load</p>	<p>Load</p>
	
<p>Load</p>	<p>Load</p>

Back  
Insert

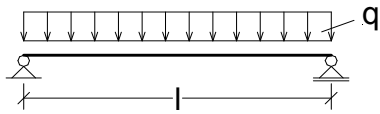

Input values:

Loading  $q = 3,00 \text{ kN/m}$   
Length  $l = 5,00 \text{ m}$

Reaction:

$$A = \frac{q \cdot l}{2} = 7,50 \text{ kN}$$

$$B = \frac{q \cdot l}{2} = 7,50 \text{ kN}$$

Internal forces:

$$M_{\max} = \frac{q \cdot l^2}{8} = 9,38 \text{ kNm}$$

at point:

$$x = \frac{l}{2} = 2,50 \text{ m}$$

Deflection:

$E = 210000,00 \text{ N/mm}^2$   
 $I_y = 25,10 \cdot 10^6 \text{ mm}^4$

$$f_{\text{Mid}} = \frac{5}{384} \cdot q \cdot (1000 \cdot l)^4 \cdot \frac{1}{E \cdot I_y} = 4,63 \text{ mm}$$

Insert  
Back

Back  
Insert

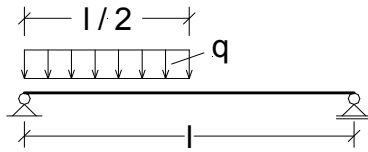

Input values:

Loading  $q = 3,00 \text{ kN/m}$   
 Length  $l = 5,00 \text{ m}$

Reaction:

$$A = \frac{3}{8} * q * l = 5,63 \text{ kN}$$

$$B = \frac{1}{8} * q * l = 1,88 \text{ kN}$$

Internal forces:

$$M_{\max} = \frac{9}{128} * q * l^2 = 5,27 \text{ kNm}$$

at point:

$$x = \frac{3}{8} * l = 1,88 \text{ m}$$

Deflection:

$E = 210000,00 \text{ N/mm}^2$   
 $I_y = 25,10 * 10^6 \text{ mm}^4$

$$f_{\text{Mid}} = \frac{5}{768} * q * (1000 * l)^4 * \frac{1}{E * I_y} = 2,32 \text{ mm}$$

Insert  
Back

Back  
Insert

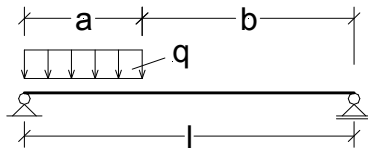

Input values:

Loading  $q = 3,00 \text{ kN/m}$   
 Length  $l = 5,00 \text{ m}$   
 Load length  $a = 2,00 \text{ m}$

$$\alpha = \frac{a}{l} = 0,40$$

Reaction:

$$A = \frac{q \cdot a}{l} \cdot \left( l - \frac{a}{2} \right) = 4,80 \text{ kN}$$

$$B = \frac{q \cdot a^2}{2 \cdot l} = 1,20 \text{ kN}$$

Internal forces:

$$M_{\max} = \frac{A^2}{2 \cdot q} = 3,84 \text{ kNm}$$

at point:

$$x = \frac{A}{q} = 1,60 \text{ m}$$

Deflection:

$E = 210000,00 \text{ N/mm}^2$   
 $I_y = 25,10 \cdot 10^6 \text{ mm}^4$

$$f_{\text{Mid}} = \frac{1}{48} \cdot q \cdot (1000 \cdot l)^4 \cdot \alpha^2 \cdot \frac{1,5 - \alpha^2}{E \cdot I_y} = 1,59 \text{ mm}$$

Insert  
Back

Back  
Insert

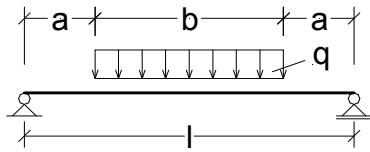

Input values:

Loading  $q =$  3,00 kN/m  
 Length  $l =$  5,00 m  
 Load length  $b =$  3,00 m

$$\alpha = \frac{l - b}{l * 2} = 0,20$$

Reaction:

$$A = \frac{q * b}{2} = 4,50 \text{ kN}$$

$$B = \frac{q * b}{2} = 4,50 \text{ kN}$$

Internal forces:

$$M_{\max} = \frac{q * b}{8} * (2 * l - b) = 7,88 \text{ kNm}$$

at point:

$$x = \frac{l}{2} = 2,50 \text{ m}$$

Deflection:

$E =$  210000,00 N/mm<sup>2</sup>  
 $I_y =$  25,10 \* 10<sup>6</sup> mm<sup>4</sup>

$$f_{\text{Mid}} = \frac{1}{384} * q * (1000 * l)^4 * \frac{5 - 24 * \alpha^2 + 16 * \alpha^4}{E * I_y} = 3,77 \text{ mm}$$

Insert  
Back

Back  
Insert

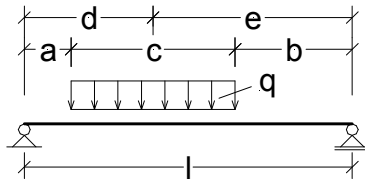

Input values:

Loading  $q = 3,00 \text{ kN/m}$   
 Length  $l = 5,00 \text{ m}$   
 Distance  $a = 1,00 \text{ m}$   
 Load length  $c = 2,00 \text{ m}$

$$b = l - a - c = 2,00 \text{ m}$$

$$\alpha = \frac{a}{l} = 0,20$$

$$\beta = \frac{b}{l} = 0,40$$

Reaction:

$$A = \frac{q \cdot c \cdot (2 \cdot b + c)}{2 \cdot l} = 3,60 \text{ kN}$$

$$B = \frac{q \cdot c \cdot (2 \cdot a + c)}{2 \cdot l} = 2,40 \text{ kN}$$

Internal forces:

$$M_{\max} = \frac{A^2}{2 \cdot q} + A \cdot a = 5,76 \text{ kNm}$$

at point:

$$x = a + \frac{A}{q} = 2,20 \text{ m}$$

Deflection:

$$E = 210000,00 \text{ N/mm}^2$$

$$I_y = 25,10 \cdot 10^6 \text{ mm}^4$$

$$f_{\text{Mid}} = \frac{1}{384} \cdot q \cdot (1000 \cdot l)^4 \cdot \frac{5 - 12 \cdot \alpha^2 + 8 \cdot \alpha^4 - 12 \cdot \beta^2 + 8 \cdot \beta^4}{E \cdot I_y} = 2,61 \text{ mm}$$

Insert  
Back



Back  
Insert

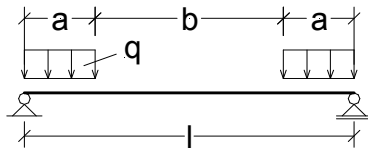

Input values:

Loading  $q = 3,00 \text{ kN/m}$   
 Length  $l = 5,00 \text{ m}$   
 Load length  $a = 1,00 \text{ m}$

$$\alpha = \frac{a}{l} = 0,20$$

Reaction:

$A = q \cdot a = 3,00 \text{ kN}$   
 $B = q \cdot a = 3,00 \text{ kN}$

Internal forces:

$$M_{\max} = \frac{1}{2} \cdot q \cdot a^2 = 1,50 \text{ kNm}$$

at point:

$$x = \frac{l}{2} = 2,50 \text{ m}$$

$(a \leq x \leq a+b)$

Deflection:

$E = 210000,00 \text{ N/mm}^2$   
 $I_y = 25,10 \cdot 10^6 \text{ mm}^4$

$$f_{\text{Mid}} = \frac{1}{24} \cdot q \cdot (1000 \cdot l)^4 \cdot \alpha^2 \cdot \frac{1,5 - \alpha^2}{E \cdot I_y} = 0,87 \text{ mm}$$

Insert  
Back

Back  
Insert

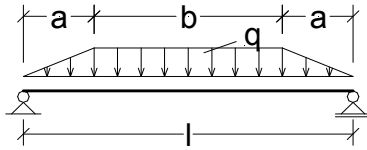

Input values:

Loading  $q = 3,00 \text{ kN/m}$   
 Length  $l = 5,00 \text{ m}$   
 Load increase length  $a = 1,00 \text{ m}$

$$\alpha = \frac{a}{l} = 0,20$$

Reaction:

$$A = \frac{q}{2} * (l - a) = 6,00 \text{ kN}$$

$$B = \frac{q}{2} * (l - a) = 6,00 \text{ kN}$$

Internal forces:

$$M_{\max} = \frac{q * l^2}{24} * (3 - 4 * \alpha^2) = 8,88 \text{ kNm}$$

at point:

$$x = \frac{l}{2} = 2,50 \text{ m}$$

Deflection:

$E = 210000,00 \text{ N/mm}^2$   
 $I_y = 25,10 * 10^6 \text{ mm}^4$

$$f_{\text{Mid}} = \frac{1}{1920} * q * (1000 * l)^4 * \frac{25 - 40 * \alpha^2 + 16 * \alpha^4}{E * I_y} = 4,34 \text{ mm}$$

Insert  
Back

Back  
Insert

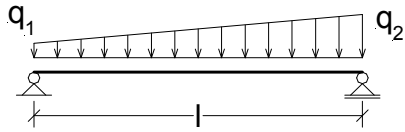

Input values:

Loading  $q_1 = 1,00 \text{ kN/m}$   
 Loading  $q_2 = 3,00 \text{ kN/m}$   
 Length  $l = 5,00 \text{ m}$

Reaction:

$$A = (2 * q_1 + q_2) * \frac{l}{6} = 4,17 \text{ kN}$$

$$B = (q_1 + 2 * q_2) * \frac{l}{6} = 5,83 \text{ kN}$$

Internal forces:

$$M_{\max} = 0,063 * (q_1 + q_2) * l^2 = 6,30 \text{ kNm}$$

at point:

$$x = 0,528 * l = 2,64 \text{ m}$$

for exact  $q_1 = 0,5 * q_2$

Deflection:

$$E = 210000,00 \text{ N/mm}^2$$

$$I_y = 25,10 * 10^6 \text{ mm}^4$$

$$f_{\text{Mid}} = \frac{5}{768} * (q_1 + q_2) * (1000 * l)^4 * \frac{1}{E * I_y} = 3,09 \text{ mm}$$

Insert  
Back

Back  
Insert

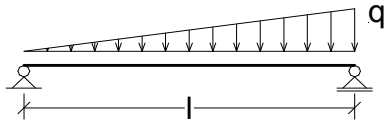

Input values:

Loading  $q = 3,00 \text{ kN/m}$   
 Length  $l = 5,00 \text{ m}$

Reaction:

$$A = \frac{1}{6} * q * l = 2,50 \text{ kN}$$

$$B = \frac{1}{3} * q * l = 5,00 \text{ kN}$$

Internal forces:

$$M_{\max} = \frac{1}{9 * \sqrt{3}} * q * l^2 = 4,81 \text{ kNm}$$

at point:

$$x = \frac{l}{\sqrt{3}} = 2,89 \text{ m}$$

Deflection:

$E = 210000,00 \text{ N/mm}^2$   
 $I_y = 25,10 * 10^6 \text{ mm}^4$

$$f_{\text{Mid}} = \frac{5}{768} * q * (1000 * l)^4 * \frac{1}{E * I_y} = 2,32 \text{ mm}$$

Insert  
Back

Back  
Insert

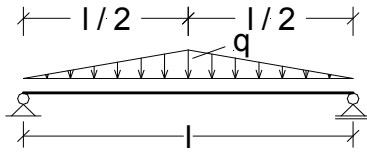

Input values:

Loading  $q = 3,00 \text{ kN/m}$   
 Length  $l = 5,00 \text{ m}$

Reaction:

$$A = \frac{1}{4} * q * l = 3,75 \text{ kN}$$

$$B = \frac{1}{4} * q * l = 3,75 \text{ kN}$$

Internal forces:

$$M_{\max} = \frac{1}{12} * q * l^2 = 6,25 \text{ kNm}$$

at point:

$$x = \frac{l}{2} = 2,50 \text{ m}$$

Deflection:

$E = 210000,00 \text{ N/mm}^2$   
 $I_y = 25,10 * 10^6 \text{ mm}^4$

$$f_{\text{Mid}} = \frac{1}{120} * q * (1000 * l)^4 * \frac{1}{E * I_y} = 2,96 \text{ mm}$$

Insert  
Back

Back  
Insert

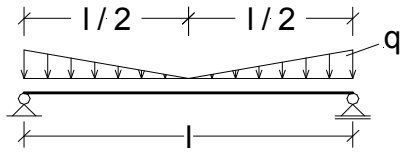

Input values:

Loading  $q = 3,00 \text{ kN/m}$   
 Length  $l = 5,00 \text{ m}$

Reaction:

$$A = \frac{1}{4} * q * l = 3,75 \text{ kN}$$

$$B = \frac{1}{4} * q * l = 3,75 \text{ kN}$$

Internal forces:

$$M_{\max} = \frac{1}{24} * q * l^2 = 3,13 \text{ kNm}$$

at point:

$$x = \frac{l}{2} = 2,50 \text{ m}$$

Deflection:

$E = 210000,00 \text{ N/mm}^2$   
 $I_y = 25,10 * 10^6 \text{ mm}^4$

$$f_{\text{Mid}} = \frac{3}{640} * q * (1000 * l)^4 * \frac{1}{E * I_y} = 1,67 \text{ mm}$$

Insert  
Back

Back  
Insert

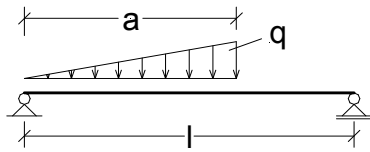

Input values:

Loading  $q =$  3,00 kN/m  
 Length  $l =$  5,00 m  
 Load length  $a =$  3,00 m

$$\alpha = \frac{a}{l} = 0,60$$

Reaction:

$$A = \frac{q \cdot a}{6} \cdot (3 - 2 \cdot \alpha) = 2,70 \text{ kN}$$

$$B = \frac{q \cdot a}{3} \cdot \alpha = 1,80 \text{ kN}$$

Internal forces:

$$M_{\max} = \frac{q \cdot a^2}{3} \cdot \sqrt{\left(1 - \frac{2}{3} \cdot \alpha\right)^3} = 4,18 \text{ kNm}$$

at point:

$$x = a \cdot \sqrt{1 - \frac{2}{3} \cdot \alpha} = 2,32 \text{ m}$$

Deflection:

$E =$  210000,00 N/mm<sup>2</sup>  
 $I_y =$  25,10\*10<sup>6</sup> mm<sup>4</sup>

$$f_{\text{Mid}} = \frac{q \cdot (1000 \cdot a)^3}{45} \cdot (1 - \alpha) \cdot \frac{5 \cdot 1000 \cdot l - 4 \cdot 1000 \cdot a}{E \cdot I_y} = 1,78 \text{ mm}$$

Insert  
Back

Back  
Insert

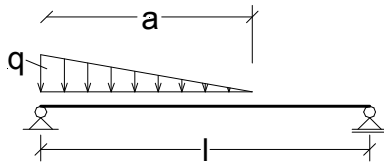

Input values:

Loading  $q =$  3,00 kN/m  
 Length  $l =$  5,00 m  
 Load length  $a =$  3,00 m

$$\alpha = \frac{a}{l} = 0,60$$

Reaction:

$$A = \frac{q \cdot a}{6} \cdot (3 - \alpha) = 3,60 \text{ kN}$$

$$B = \frac{q \cdot a}{6} \cdot \alpha = 0,90 \text{ kN}$$

Internal forces:

$$M_{\max} = \frac{q \cdot a^2}{6 \cdot l} \cdot \left( l - a + \frac{2}{3} \cdot a \cdot \sqrt{\frac{\alpha}{3}} \right) = 2,60 \text{ kNm}$$

Deflection:

$E =$  210000,00 N/mm<sup>2</sup>  
 $I_y =$  25,10\*10<sup>6</sup> mm<sup>4</sup>

$$f_{\text{Mid}} = \frac{q \cdot (1000 \cdot a)^3}{360} \cdot (1 - \alpha) \cdot \frac{20 \cdot 1000 \cdot l - 13 \cdot 1000 \cdot a}{E \cdot I_y} = 1,04 \text{ mm}$$

Insert  
Back



Back  
Insert

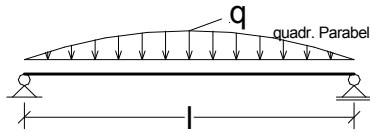

Input values:

Loading  $q = 3,00 \text{ kN/m}$   
 Length  $l = 5,00 \text{ m}$

Reaction:

$$A = \frac{q \cdot l}{3} = 5,00 \text{ kN}$$

$$B = \frac{q \cdot l}{3} = 5,00 \text{ kN}$$

Internal forces:

$$M_{\max} = \frac{5}{48} \cdot q \cdot l^2 = 7,81 \text{ kNm}$$

at point:

$$x = \frac{l}{2} = 2,50 \text{ m}$$

Deflection:

$E = 210000,00 \text{ N/mm}^2$   
 $I_y = 25,10 \cdot 10^6 \text{ mm}^4$

$$f_{\text{Mid}} = \frac{61}{5760} \cdot q \cdot (1000 \cdot l)^4 \cdot \frac{1}{E \cdot I_y} = 3,77 \text{ mm}$$

Insert  
Back

Back  
Insert

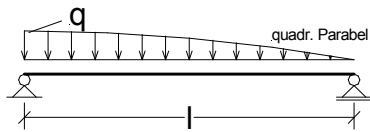

Input values:

Loading  $q = 3,00 \text{ kN/m}$   
 Length  $l = 5,00 \text{ m}$

Reaction:

$$A = \frac{q \cdot l}{2,4} = 6,25 \text{ kN}$$

$$B = \frac{q \cdot l}{4} = 3,75 \text{ kN}$$

Internal forces:

$$M_{\max} = \frac{1}{11,15} \cdot q \cdot l^2 = 6,73 \text{ kNm}$$

at point:

$$x = 0,446 \cdot l = 2,23 \text{ m}$$

Deflection:

$E = 210000,00 \text{ N/mm}^2$   
 $I_y = 25,10 \cdot 10^6 \text{ mm}^4$

$$f_{\text{Mid}} = \frac{11}{1200} \cdot q \cdot (1000 \cdot l)^4 \cdot \frac{1}{E \cdot I_y} = 3,26 \text{ mm}$$

Insert  
Back

Back  
Insert

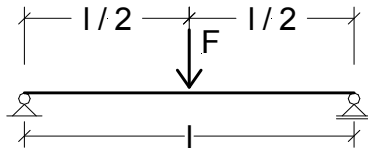

Input values:

Force  $F = 10,00 \text{ kN}$   
 Length  $l = 5,00 \text{ m}$

Reaction:

$$A = \frac{F}{2} = 5,00 \text{ kN}$$

$$B = \frac{F}{2} = 5,00 \text{ kN}$$

Internal forces:

$$M_{\max} = \frac{F \cdot l}{4} = 12,50 \text{ kNm}$$

at point:

$$x = \frac{l}{2} = 2,50 \text{ m}$$

Deflection:

$E = 210000,00 \text{ N/mm}^2$   
 $I_y = 25,10 \cdot 10^6 \text{ mm}^4$

$$f_{\text{Mid}} = \frac{1}{48} \cdot F \cdot (1000 \cdot l)^3 \cdot \frac{1000}{E \cdot I_y} = 4,94 \text{ mm}$$

Insert  
Back

Back  
Insert

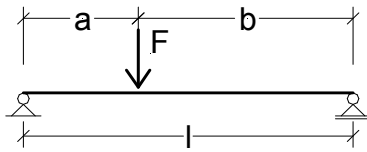

Input values:

Force F = 10,00 kN  
 Length l = 5,00 m  
 Lastabstand a = 2,00 m

$$b = l - a = 3,00 \text{ m}$$

$$\alpha = \frac{a}{l} = 0,40$$

Reaction:

$$A = \frac{F \cdot b}{l} = 6,00 \text{ kN}$$

$$B = \frac{F \cdot a}{l} = 4,00 \text{ kN}$$

Internal forces:

$$M_{\max} = \frac{F \cdot a \cdot b}{l} = 12,00 \text{ kNm}$$

at point:

$$x = a = 2,00 \text{ m}$$

Deflection:

E = 210000,00 N/mm<sup>2</sup>  
 I<sub>y</sub> = 25,10\*10<sup>6</sup> mm<sup>4</sup>

$$f_{\text{Mid}} = \frac{1}{48} \cdot F \cdot (1000 \cdot l)^3 \cdot \frac{(3 \cdot \alpha - 4 \cdot \alpha^3) \cdot 1000}{E \cdot I_y} = 4,66 \text{ mm}$$

Insert  
Back

Back  
Insert

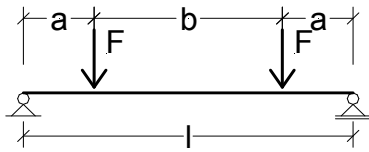

Input values:

Force  $F = 10,00 \text{ kN}$   
 Length  $l = 5,00 \text{ m}$   
 Lastabstand  $a = 2,00 \text{ m}$

$$b = l - 2 * a = 1,00 \text{ m}$$

$$\alpha = \frac{a}{l} = 0,40$$

Reaction:

$$A = F = 10,00 \text{ kN}$$

$$B = F = 10,00 \text{ kN}$$

Internal forces:

$$M_{\max} = F * a = 20,00 \text{ kNm}$$

at point:

$$x = \frac{l}{2} = 2,50 \text{ m}$$

$(a \leq x \leq a+b)$

Deflection:

$$E = 210000,00 \text{ N/mm}^2$$

$$I_y = 25,10 * 10^6 \text{ mm}^4$$

$$f_{\text{Mid}} = \frac{1}{24} * F * (1000 * l)^3 * \frac{(3 * \alpha - 4 * \alpha^3) * 1000}{E * I_y} = 9,33 \text{ mm}$$

Insert  
Back

Back  
Insert

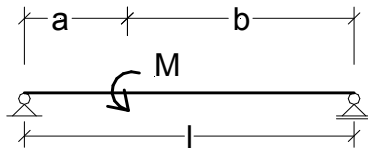

Input values:

Length  $l =$  5,00 m  
 Moment  $M =$  10,00 kNm  
 Distance  $a =$  2,00 m

$$b = l - 2 * a = 1,00 \text{ m}$$

$$\alpha = \frac{a}{l} = 0,40$$

Reaction:

$$A = \frac{M}{l} = 2,00 \text{ kN}$$

$$B = -\frac{M}{l} = -2,00 \text{ kN}$$

Internal forces:

$$M_{\max} = \text{IF} \left( a \geq \frac{l}{2}; \frac{M * a}{l}; \frac{-M * b}{l} \right) = -2,00 \text{ kNm}$$

Insert  
Back

Back  
Insert

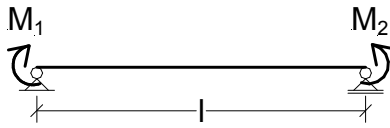

Input values:

Length  $l =$  5,00 m  
 Moment  $M_1 =$  5,00 kNm  
 Moment  $M_2 =$  8,00 kNm

Reaction:

$$A = \frac{M_2 - M_1}{l} = 0,60 \text{ kN}$$

$$B = -\frac{M_2 - M_1}{l} = -0,60 \text{ kN}$$

Internal forces:

$E =$  210000,00 N/mm<sup>2</sup>  
 $I_y =$  25,10\*10<sup>6</sup> mm<sup>4</sup>

$$f_{\text{Mid}} = \frac{1}{16} * (1000 * l)^2 * (M_1 + M_2) * \frac{10^6}{E * I_y} = 3,85 \text{ mm}$$

Insert  
Back

## Templates structural formulae

Simple beam with cantilever

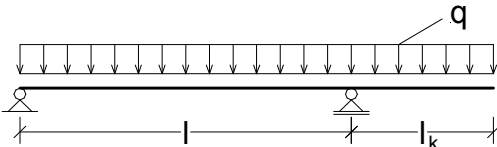
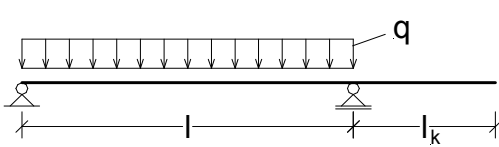
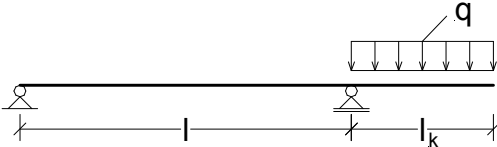
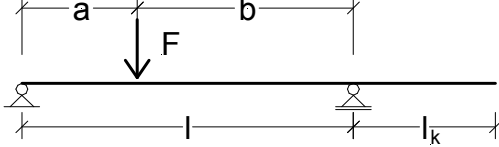
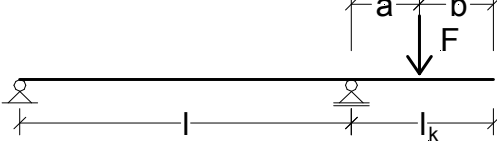
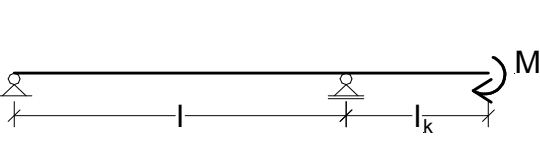

	
<p>Load</p>	<p>Load</p>
	
<p>Load</p>	<p>Load</p>
	
<p>Load</p>	<p>Load</p>

Back  
Insert

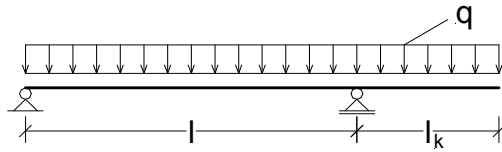

Input values:

Length  $l = 5,00 \text{ m}$   
 Loading  $q = 3,00 \text{ kN/m}$   
 Cantilever length  $l_k = 2,00 \text{ m}$

Reaction:

$$A = \frac{q}{2} \cdot \left( l - \frac{l_k^2}{l} \right) = 6,30 \text{ kN}$$

$$B = \frac{q}{2} \cdot \left( l + \frac{l_k^2}{l} + 2 \cdot l_k \right) = 14,70 \text{ kN}$$

Internal forces:

$$M_{\text{panel,max}} = \frac{A^2}{2 \cdot q} = 6,62 \text{ kNm}$$

$$M_{\text{Cant}} = \frac{-q \cdot l_k^2}{2} = -6,00 \text{ kNm}$$

Deflection:

$E = 210000,00 \text{ N/mm}^2$   
 $I_y = 25,10 \cdot 10^6 \text{ mm}^4$

$$f_{\text{Mid}} = \frac{q \cdot l^2}{32} \cdot \left( \frac{5}{12} \cdot l^2 - l_k^2 \right) \cdot \frac{10^{12}}{E \cdot I_y} = 2,85 \text{ mm}$$

$$f_{\text{Cant}} = \frac{q \cdot l_k^3}{24} \cdot \left( 3 \cdot l_k^3 + 4 \cdot l \cdot l_k^2 - l^3 \right) \cdot \frac{10^{12}}{E \cdot I_y} = -1,00 \text{ mm}$$

Insert  
Back

Back  
Insert

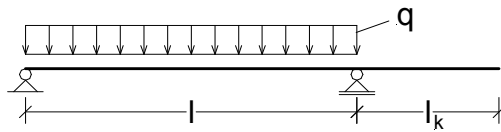

Input values:

Length  $l = 5,00 \text{ m}$   
 Loading  $q = 3,00 \text{ kN/m}$   
 Cantilever length  $l_k = 2,00 \text{ m}$

Reaction:

$$A = \frac{q \cdot l}{2} = 7,50 \text{ kN}$$

$$B = \frac{q \cdot l}{2} = 7,50 \text{ kN}$$

Internal forces:

$$M_{\text{panel,max}} = \frac{q \cdot l^2}{8} = 9,38 \text{ kNm}$$

$$M_{\text{Cant}} = 0,00 \text{ kNm}$$

Deflection:

$E = 210000,00 \text{ N/mm}^2$   
 $I_y = 25,10 \cdot 10^6 \text{ mm}^4$

$$f_{\text{Mid}} = \frac{5}{384} \cdot q \cdot l^4 \cdot \frac{10^{12}}{E \cdot I_y} = 4,63 \text{ mm}$$

$$f_{\text{Cant}} = \frac{-1}{24} \cdot q \cdot l^3 \cdot l_k \cdot \frac{10^{12}}{E \cdot I_y} = -5,93 \text{ mm}$$

Insert  
Back

Back  
Insert

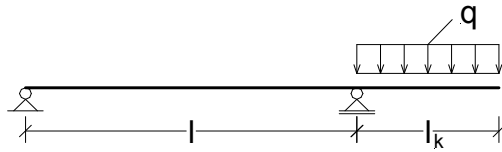

Input values:

Length  $l = 5,00 \text{ m}$   
 Loading  $q = 3,00 \text{ kN/m}$   
 Cantilever length  $l_k = 2,00 \text{ m}$

Reaction:

$$A = \frac{-q \cdot l_k^2}{2 \cdot l} = -1,20 \text{ kN}$$

$$B = q \cdot l_k \cdot \left(1 + \frac{l_k}{2 \cdot l}\right) = 7,20 \text{ kN}$$

Internal forces:

$$M_{\text{Cant}} = \frac{-q \cdot l_k^2}{2} = -6,00 \text{ kNm}$$

Deflection:

$E = 210000,00 \text{ N/mm}^2$   
 $I_y = 25,10 \cdot 10^6 \text{ mm}^4$

$$f_{\text{Mid}} = \frac{-1}{32} \cdot q \cdot l^2 \cdot l_k^2 \cdot \frac{10^{12}}{E \cdot I_y} = -1,78 \text{ mm}$$

$$f_{\text{Cant}} = \frac{1}{24} \cdot q \cdot l_k^3 \cdot (4 \cdot l + 3 \cdot l_k) \cdot \frac{10^{12}}{E \cdot I_y} = 4,93 \text{ mm}$$

Insert  
Back

Back  
Insert

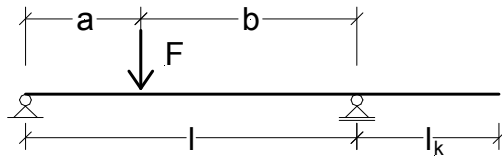

Input values:

Length  $l =$  5,00 m  
 Force  $F =$  10,00 kN  
 Cantilever length  $l_k =$  2,00 m  
 Distance  $a =$  2,00 m

$$b = l - a = 3,00 \text{ m}$$

$$\alpha = \frac{a}{l} = 0,40$$

Reaction:

$$A = \frac{F \cdot b}{l} = 6,00 \text{ kN}$$

$$B = \frac{F \cdot a}{l} = 4,00 \text{ kN}$$

Internal forces:

$$M_{\max} = \frac{F \cdot a \cdot b}{l} = 12,00 \text{ kNm}$$

Deflection:

$E =$  210000,00 N/mm<sup>2</sup>  
 $I_y =$  25,10\*10<sup>6</sup> mm<sup>4</sup>

$$f_{\text{Mid}} = \frac{F \cdot l^3}{48} \cdot (3 \cdot \alpha - 4 \cdot \alpha^3) \cdot \frac{10^{12}}{E \cdot I_y} = 4,66 \text{ mm}$$

$$f_{\text{Cant}} = \frac{-F \cdot a \cdot b \cdot l_k}{6 \cdot l} \cdot (l + a) \cdot \frac{10^{12}}{E \cdot I_y} = -5,31 \text{ mm}$$

Insert  
Back

Back  
Insert

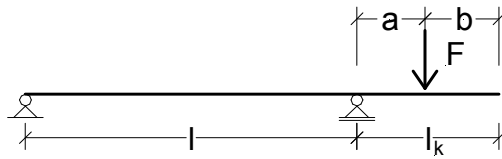

Input values:

Length  $l = 5,00$  m  
 Force  $F = 10,00$  kN  
 Cantilever length  $l_k = 2,00$  m  
 Distance  $a = 2,00$  m

Reaction:

$$A = \frac{-F \cdot a}{l} = -4,00 \text{ kN}$$

$$B = \frac{F \cdot (a + l)}{l} = 14,00 \text{ kN}$$

Internal forces:

$$M_{\text{Cant}} = -F \cdot a = -20,00 \text{ kNm}$$

Deflection:

$E = 210000,00$  N/mm<sup>2</sup>  
 $I_y = 25,10 \cdot 10^6$  mm<sup>4</sup>

$$f_{\text{Mid}} = \frac{-1}{16} \cdot F \cdot l^2 \cdot a \cdot \frac{10^{12}}{E \cdot I_y} = -5,93 \text{ mm}$$

$$f_{\text{Cant}} = \frac{1}{6} \cdot F \cdot a \cdot \left( 2 \cdot l \cdot l_k + 3 \cdot l_k \cdot a - a^2 \right) \cdot \frac{10^{12}}{E \cdot I_y} = 17,71 \text{ mm}$$

Insert  
Back

Back  
Insert

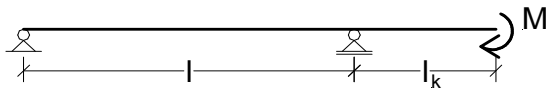

Input values:

Length  $l = 5,00 \text{ m}$   
 Moment  $M = 10,00 \text{ kNm}$   
 Cantilever length  $l_k = 2,00 \text{ m}$

Reaction:

$$A = \frac{-M}{l} = -2,00 \text{ kN}$$

$$B = \frac{M}{l} = 2,00 \text{ kN}$$

Internal forces:

$$M_{\text{Cant}} = -M = -10,00 \text{ kNm}$$

Deflection:

$E = 210000,00 \text{ N/mm}^2$   
 $I_y = 25,10 \cdot 10^6 \text{ mm}^4$

$$f_{\text{Mid}} = \frac{-1}{16} * M * l^2 * \frac{10^{12}}{E * I_y} = -2,96 \text{ mm}$$

$$f_{\text{Cant}} = \left( \frac{l}{3} + \frac{l_k}{2} \right) * M * l_k * \frac{10^{12}}{E * I_y} = 10,12 \text{ mm}$$

Insert  
Back

## Templates structural formulae

Constrained simple beam

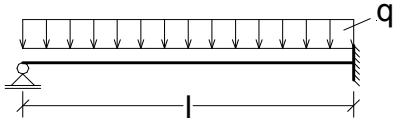
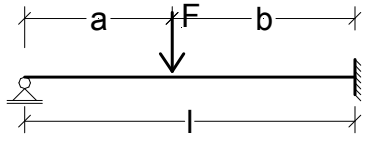
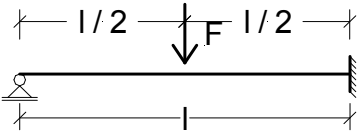
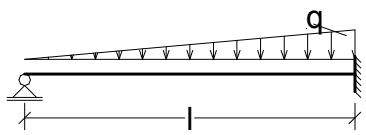
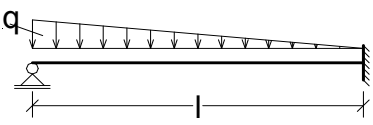
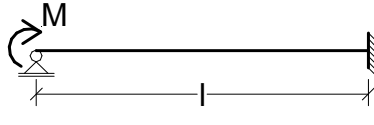
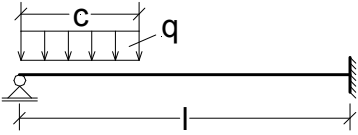
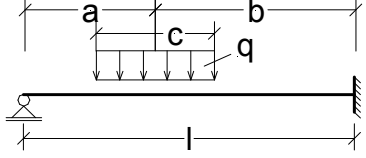
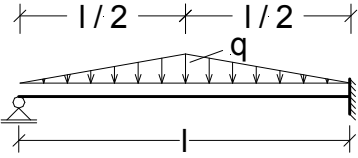
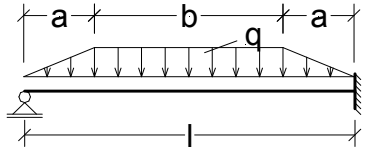

	
<p>Load</p>	<p>Load</p>
	
<p>Load</p>	<p>Load</p>
	
<p>Load</p>	<p>Load</p>
	
<p>Load</p>	<p>Load</p>
	
<p>Load</p>	<p>Load</p>

Back  
Insert

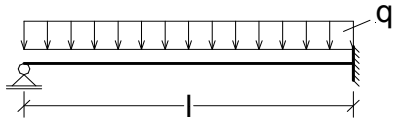

Input values:

Loading  $q =$  3,00 kN/m  
 Length  $l =$  5,00 m

Reaction:

$$A = \frac{3}{8} * q * l = 5,63 \text{ kN}$$

$$B = \frac{5}{8} * q * l = 9,38 \text{ kN}$$

Internal forces:

$$M_{\max} = \frac{9}{128} * q * l^2 = 5,27 \text{ kNm}$$

$$M_{\text{Rest}} = \frac{-q * l^2}{8} = -9,38 \text{ kNm}$$

Deflection:

$E =$  210000,00 N/mm<sup>2</sup>  
 $I_y =$  25,10\*10<sup>6</sup> mm<sup>4</sup>

$$f = \frac{2}{369} * q * (1000 * l)^4 * \frac{1}{E * I_y} = 1,93 \text{ mm}$$

Insert  
Back

Back  
Insert

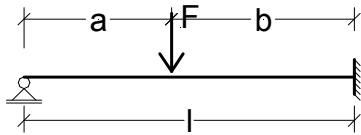

Input values:

Force  $F =$  10,00 kN

Length  $l =$  5,00 m

Distance  $a =$  2,00 m

$b =$   $l - a =$  3,00 m

Reaction:

$$A = \frac{F \cdot b^2}{2 \cdot l^3} \cdot (a + 2 \cdot l) = 4,32 \text{ kN}$$

$$B = F - A = 5,68 \text{ kN}$$

Internal forces:

$$M_{\max} = \frac{F \cdot a \cdot b^3}{2 \cdot l^3} \cdot (3 \cdot a + 2 \cdot b) = 25,92 \text{ kNm}$$

$$M_{\text{Rest}} = \frac{-F \cdot a \cdot b}{2 \cdot l} \cdot \left(1 + \frac{a}{l}\right) = -8,40 \text{ kNm}$$

Deflection:

$E =$  210000,00 N/mm<sup>2</sup>

$I_y =$  25,10\*10<sup>6</sup> mm<sup>4</sup>

$$f = \frac{F \cdot a^2 \cdot b^3}{12 \cdot l^2 \cdot E \cdot I_y} \cdot \left(3 + \frac{a}{l}\right) \cdot 10^{12} = 2,32 \text{ mm}$$

Insert  
Back

Back  
Insert

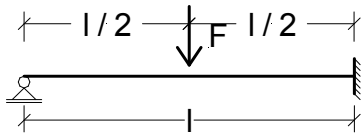

Input values:

Force  $F =$  10,00 kN  
Length  $l =$  5,00 m

Reaction:

$$A = \frac{5}{16} * F = 3,13 \text{ kN}$$

$$B = \frac{11}{16} * F = 6,88 \text{ kN}$$

Internal forces:

$$M_{\max} = \frac{5}{32} * F * l = 7,81 \text{ kNm}$$

$$M_{\text{Rest}} = \frac{-3}{16} * F * l = -9,38 \text{ kNm}$$

Deflection:

$E =$  210000,00 N/mm<sup>2</sup>  
 $I_y =$  25,10\*10<sup>6</sup> mm<sup>4</sup>

$$f = \frac{1}{48 * \sqrt{5}} * \frac{F * l^3}{E * I_y} * 10^{12} = 2,21 \text{ mm}$$

Insert  
Back

Back  
Insert

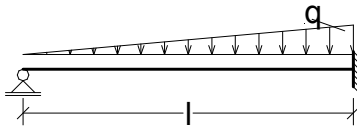

Input values:

Loading  $q = 3,00 \text{ kN/m}$   
 Length  $l = 5,00 \text{ m}$

Reaction:

$$A = \frac{1}{10} * q * l = 1,50 \text{ kN}$$

$$B = \frac{2}{5} * q * l = 6,00 \text{ kN}$$

Internal forces:

$$M_{\max} = \frac{q * l^2}{33,54} = 2,24 \text{ kNm}$$

$$M_{\text{Rest}} = \frac{-q * l^2}{15} = -5,00 \text{ kNm}$$

Deflection:

$E = 210000,00 \text{ N/mm}^2$   
 $I_y = 25,10 * 10^6 \text{ mm}^4$

$$f = \frac{q * l^4}{419 * E * I_y} * 10^{12} = 0,85 \text{ mm}$$

Insert  
Back

Back  
Insert

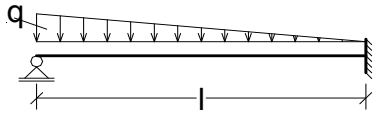

Input values:

Loading  $q = 3,00 \text{ kN/m}$   
 Length  $l = 5,00 \text{ m}$

Reaction:

$$A = \frac{11}{40} * q * l = 4,13 \text{ kN}$$

$$B = \frac{9}{40} * q * l = 3,38 \text{ kN}$$

Internal forces:

$$M_{\max} = \frac{q * l^2}{23,6} = 3,18 \text{ kNm}$$

$$M_{\text{Rest}} = \frac{-7 * q * l^2}{120} = -4,38 \text{ kNm}$$

Deflection:

$E = 210000,00 \text{ N/mm}^2$   
 $I_y = 25,10 * 10^6 \text{ mm}^4$

$$f = \frac{q * l^4}{328,1 * E * I_y} * 10^{12} = 1,08 \text{ mm}$$

Insert  
Back

Back  
Insert

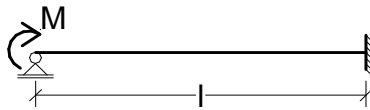

Input values:

Length  $l = 5,00 \text{ m}$   
 Moment  $M = 10,00 \text{ kNm}$

Reaction:

$$A = \frac{-3}{2} \cdot \frac{M}{l} = -3,00 \text{ kN}$$

$$B = -A = 3,00 \text{ kN}$$

Internal forces:

$$M_{\max} = M = 10,00 \text{ kNm}$$

$$M_{\text{Rest}} = \frac{-M}{2} = -5,00 \text{ kNm}$$

Deflection:

$E = 210000,00 \text{ N/mm}^2$   
 $I_y = 25,10 \cdot 10^6 \text{ mm}^4$

$$f = \frac{M}{2 \cdot E \cdot I_y} \cdot 10^{12} = 0,95 \text{ mm}$$

Insert  
Back

Back  
Insert

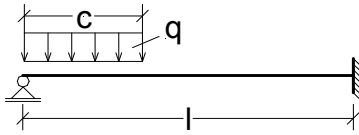

Input values:

Loading  $q =$  3,00 kN/m

Length  $l =$  5,00 m

Load length  $c =$  2,00 m

$$\gamma = \frac{c}{l} = 0,40$$

Rigid retaining torques:

$$M_{\text{Rest}} = -0,125 * q * c^2 * (2 - \gamma) = -2,40 \text{ kNm}$$

Insert  
Back



Back  
Insert

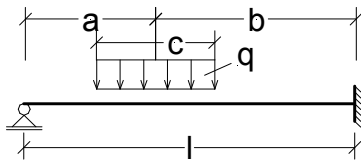

Input values:

Loading  $q = 3,00 \text{ kN/m}$   
 Length  $l = 5,00 \text{ m}$   
 Load length  $c = 2,00 \text{ m}$   
 Distance  $a = 1,00 \text{ m}$

$$\alpha = \frac{a}{l} = 0,20$$

$$\gamma = \frac{c}{l} = 0,40$$

Rigid retaining torques:

$$M_{\text{Rest}} = -0,5 * q * a * c * (2 - \alpha^2 - 0,25 * \gamma^2) = -5,76 \text{ kNm}$$

Insert  
Back

Back  
Insert

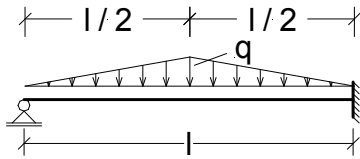

Input values:

Loading  $q =$  3,00 kN/m  
Length  $l =$  5,00 m

Rigid retaining torques:

$$M_{\text{Rest}} = \frac{-5}{64} * q * l^2 = -5,86 \text{ kNm}$$

Insert  
Back

Back  
Insert

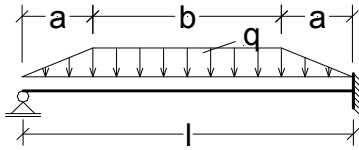

Input values:

Loading  $q =$  3,00 kN/m  
 Length  $l =$  5,00 m  
 Load increase length  $a =$  1,00 m

$$\alpha = \frac{a}{l} = 0,20$$

Rigid retaining torques:

$$M_{\text{Rest}} = \frac{-q \cdot l^2}{8} \cdot (1 - 2 \cdot \alpha^2 + \alpha^3) = -8,70 \text{ kNm}$$

Insert  
Back

## Templates structural formulae

Fixed end beam

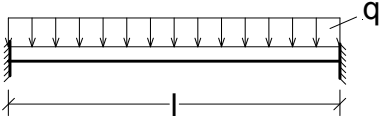
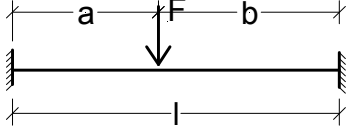
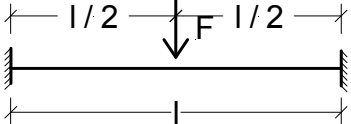
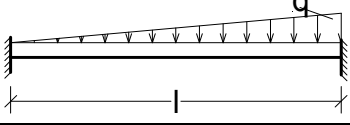
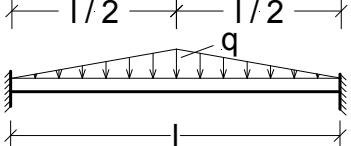
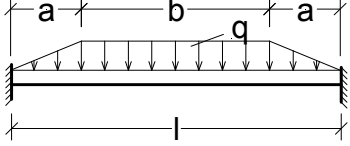
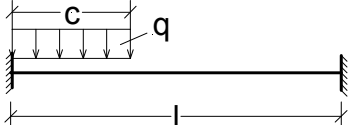
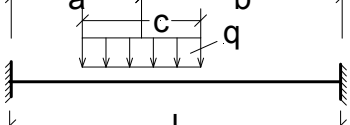
	
<p>Load</p>	<p>Load</p>
	
<p>Load</p>	<p>Load</p>
	
<p>Load</p>	<p>Load</p>
	
<p>Load</p>	<p>Load</p>

Back  
Insert

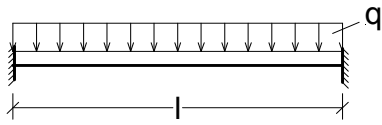

Input values:

Loading  $q = 3,00 \text{ kN/m}$   
 Length  $l = 5,00 \text{ m}$

Reaction:

$$A = \frac{q \cdot l}{2} = 7,50 \text{ kN}$$

$$B = \frac{q \cdot l}{2} = 7,50 \text{ kN}$$

Internal forces:

$$M_{\max} = \frac{q \cdot l^2}{24} = 3,13 \text{ kNm}$$

$$M_{\text{Rest}} = \frac{-q \cdot l^2}{12} = -6,25 \text{ kNm}$$

Deflection:

$E = 210000,00 \text{ N/mm}^2$   
 $I_y = 25,10 \cdot 10^6 \text{ mm}^4$

$$f = \frac{1}{384} \cdot q \cdot (1000 \cdot l)^4 \cdot \frac{1}{E \cdot I_y} = 0,93 \text{ mm}$$

Insert  
Back

Back  
Insert

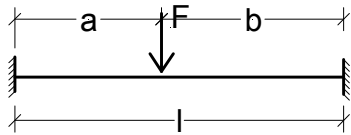

Input values:

Length  $l =$  5,00 m  
 Force  $F =$  10,00 kN  
 Distance  $a =$  2,00 m

$$b = l - a = 3,00 \text{ m}$$

$$\alpha = \frac{a}{l} = 0,40$$

$$\beta = \frac{b}{l} = 0,60$$

Reaction:

$$A = \frac{F \cdot b^2}{l^3} \cdot (l + 2 \cdot a) = 6,48 \text{ kN}$$

$$B = F - A = 3,52 \text{ kN}$$

Internal forces:

$$M_{\max} = \frac{2 \cdot F \cdot a \cdot b^3}{l^3} = 8,64 \text{ kNm}$$

$$M_{a, \text{Rest}} = -\alpha^2 \cdot \beta^2 \cdot F \cdot l = -7,20 \text{ kNm}$$

$$M_{b, \text{Rest}} = -\alpha^2 \cdot \beta^2 \cdot F \cdot l = -4,80 \text{ kNm}$$

Deflection:

$E =$  210000,00 N/mm<sup>2</sup>  
 $I_y =$  25,10 \* 10<sup>6</sup> mm<sup>4</sup>

$$f = \frac{F \cdot a^3 \cdot b^3}{3 \cdot l^3 \cdot E \cdot I_y} \cdot 10^{12} = 1,09 \text{ mm}$$

Insert  
Back

Back  
Insert

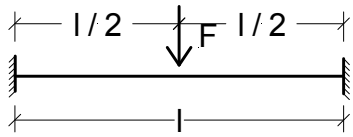

Input values:

Force  $F = 10,00 \text{ kN}$   
 Length  $l = 5,00 \text{ m}$

Reaction:

$$A = \frac{F}{2} = 5,00 \text{ kN}$$

$$B = \frac{F}{2} = 5,00 \text{ kN}$$

Internal forces:

$$M_{\max} = \frac{F \cdot l}{8} = 6,25 \text{ kNm}$$

$$M_{\text{Rest}} = \frac{-F \cdot l}{8} = -6,25 \text{ kNm}$$

Deflection:

$E = 210000,00 \text{ N/mm}^2$   
 $I_y = 25,10 \cdot 10^6 \text{ mm}^4$

$$f = \frac{1}{192} \cdot \frac{F \cdot l^3}{E \cdot I_y} \cdot 10^{12} = 1,24 \text{ mm}$$

Insert  
Back



Back  
Insert

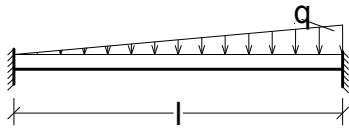

Input values:

Loading $q =$	3,00 kN/m
Length $l =$	5,00 m
$\alpha =$	1,00
$\beta =$	1,00

Reaction:

$A =$	$\frac{3}{20} * q * l$	$=$	2,25 kN
$B =$	$\frac{7}{20} * q * l$	$=$	5,25 kN

Internal forces:

$M_{\max} =$	$\frac{q * l^2}{46,64}$	$=$	1,61 kNm
$M_{a, \text{Rest}} =$	$\frac{-q * l^2}{30}$	$=$	-2,50 kNm
$M_{b, \text{Rest}} =$	$\frac{-q * l^2}{30} * 1,5$	$=$	-3,75 kNm

Deflection:

$E =$	210000,00 N/mm <sup>2</sup>
$I_y =$	25,10 * 10 <sup>6</sup> mm <sup>4</sup>

$f =$	$\frac{q * l^4}{764,2 * E * I_y} * 10^{12}$	$=$	0,47 mm
-------	---	-----	---------

Insert  
Back

Back  
Insert

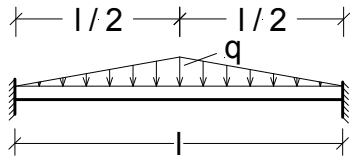

Input values:

Loading  $q = 3,00 \text{ kN/m}$   
Length  $l = 5,00 \text{ m}$

Reaction:

$$A = \frac{q \cdot l}{4} = 3,75 \text{ kN}$$

$$B = \frac{q \cdot l}{4} = 3,75 \text{ kN}$$

Internal forces:

$$M_{\max} = \frac{q \cdot l^2}{32} = 2,34 \text{ kNm}$$

$$M_{\text{Rest}} = \frac{-5 \cdot q \cdot l^2}{96} = -3,91 \text{ kNm}$$

Deflection:

$E = 210000,00 \text{ N/mm}^2$   
 $I_y = 25,10 \cdot 10^6 \text{ mm}^4$

$$f = \frac{q \cdot l^4}{3840 \cdot E \cdot I_y} \cdot 10^{12} = 0,09 \text{ mm}$$

Insert  
Back

Back  
Insert

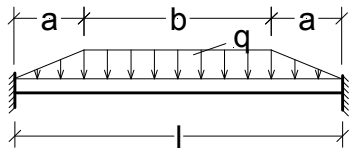

Input values:

Loading  $q = 3,00 \text{ kN/m}$   
 Length  $l = 5,00 \text{ m}$   
 Load increase length  $a = 1,00 \text{ m}$

$$\alpha = \frac{a}{l} = 0,20$$

Reaction:

$$A = \frac{q}{2} * (l - a) = 6,00 \text{ kN}$$

$$B = \frac{q}{2} * (l - a) = 6,00 \text{ kN}$$

Internal forces:

$$M_{\max} = \frac{q * l^2}{24} * (1 - 2 * \alpha^3) = 3,08 \text{ kNm}$$

$$M_{\text{Rest}} = \frac{-q * l^2}{12} * (1 - 2 * \alpha^2 + \alpha^3) = -5,80 \text{ kNm}$$

Deflection:

$E = 210000,00 \text{ N/mm}^2$   
 $I_y = 25,10 * 10^6 \text{ mm}^4$

$$f = \frac{q * l^4}{1920 * E * I_y} * (5 - 20 * \alpha^3 + 17 * \alpha^4) * 10^{12} = 0,90 \text{ mm}$$

Insert  
Back

Back  
Insert

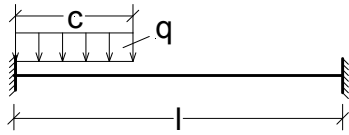

Input values:

Loading  $q =$  3,00 kN/m

Length  $l =$  5,00 m

Load length  $c =$  2,00 m

$$\gamma = \frac{c}{l} = 0,40$$

Rigid retaining torques:

$$M_1 = -q \cdot c^2 \cdot (0,5 - 0,667 \cdot \gamma + 0,25 \cdot \gamma^2) = -3,28 \text{ kNm}$$

$$M_2 = -q \cdot c^2 \cdot \gamma \cdot (0,333 - 0,25 \cdot \gamma) = -1,12 \text{ kNm}$$

Insert  
Back

Back  
Insert

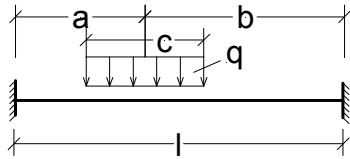

Input values:

Loading q = 3,00 kN/m  
 Length l = 5,00 m  
 Load length c = 2,00 m  
 Distance a = 1,00 m

$$b = l - a = 4,00 \text{ m}$$

$$\alpha = \frac{a}{l} = 0,20$$

$$\beta = \frac{b}{l} = 0,80$$

$$\gamma = \frac{c}{l} = 0,40$$

Rigid retaining torques:



$$M_1 = -q \cdot c \cdot l \cdot \left( \alpha \cdot \beta^2 + \frac{\gamma^2}{12} \cdot (1 - 3 \cdot \beta) \right) = -3,28 \text{ kNm}$$

$$M_2 = -q \cdot c \cdot l \cdot \left( \alpha^2 \cdot \beta + \frac{\gamma^2}{12} \cdot (1 - 3 \cdot \alpha) \right) = -1,12 \text{ kNm}$$

Insert  
Back

## Templates structural formulae

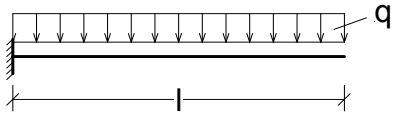
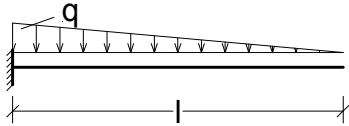
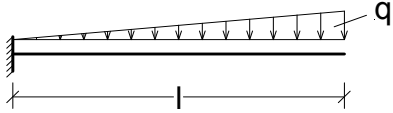
Cantilever

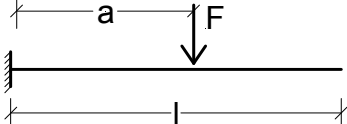
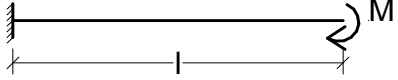
	
<p>Load</p>	<p>Load</p>
	
<p>Load</p>	<p>Load</p>
	
<p>Load</p>	<p>Load</p>

Back  
Insert

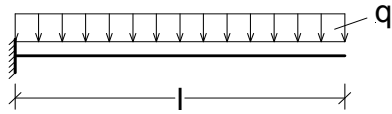

Input values:

Loading  $q = 3,00 \text{ kN/m}$   
 Length  $l = 5,00 \text{ m}$

Reaction:

$$A = q \cdot l = 15,00 \text{ kN}$$

Internal forces:

$$M_{\max} = \frac{-q \cdot l^2}{2} = -37,50 \text{ kNm}$$

Deflection:

$E = 210000,00 \text{ N/mm}^2$   
 $I_y = 25,10 \cdot 10^6 \text{ mm}^4$

$$f = \frac{q \cdot (1000 \cdot l)^4}{8} \cdot \frac{1}{E \cdot I_y} = 44,46 \text{ mm}$$

$$\varphi = \frac{q \cdot (1000 \cdot l)^3}{6} \cdot \frac{1}{E \cdot I_y} = 11,86 \cdot 10^{-3}$$

Insert  
Back



Back  
Insert

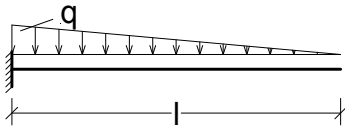

Input values:

Loading  $q = 3,00 \text{ kN/m}$   
 Length  $l = 5,00 \text{ m}$

Reaction:

$$A = \frac{q \cdot l}{2} = 7,50 \text{ kN}$$

Internal forces:

$$M_{\max} = \frac{-q \cdot l^2}{6} = -12,50 \text{ kNm}$$

Deflection:

$E = 210000,00 \text{ N/mm}^2$   
 $I_y = 25,10 \cdot 10^6 \text{ mm}^4$

$$f = \frac{q \cdot (1000 \cdot l)^4}{30} \cdot \frac{1}{E \cdot I_y} = 11,86 \text{ mm}$$

$$\varphi = \frac{q \cdot (1000 \cdot l)^3}{24} \cdot \frac{1}{E \cdot I_y} = 2,96 \cdot 10^{-3}$$

Insert  
Back

Back  
Insert

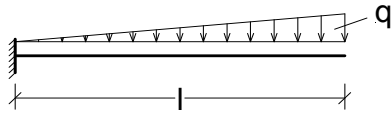

Input values:

Loading  $q = 3,00 \text{ kN/m}$   
 Length  $l = 5,00 \text{ m}$

Reaction:

$$A = \frac{q \cdot l}{2} = 7,50 \text{ kN}$$

Internal forces:

$$M_{\max} = \frac{-q \cdot l^2}{3} = -25,00 \text{ kNm}$$

Deflection:

$E = 210000,00 \text{ N/mm}^2$   
 $I_y = 25,10 \cdot 10^6 \text{ mm}^4$

$$f = \frac{11 \cdot q \cdot (1000 \cdot l)^4}{120} \cdot \frac{1}{E \cdot I_y} = 32,61 \text{ mm}$$

$$\varphi = \frac{q \cdot (1000 \cdot l)^3}{8} \cdot \frac{1}{E \cdot I_y} = 8,89 \cdot 10^{-3}$$

Insert  
Back

Back  
Insert

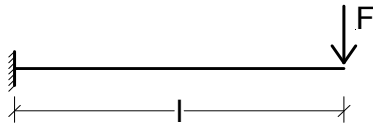

Input values:

Force  $F = 10,00 \text{ kN}$   
 Length  $l = 5,00 \text{ m}$

Reaction:

$A = F = 10,00 \text{ kN}$

Internal forces:

$M_{\max} = -F \cdot l = -50,00 \text{ kNm}$

Deflection:

$E = 210000,00 \text{ N/mm}^2$   
 $I_y = 25,10 \cdot 10^6 \text{ mm}^4$

$$f = \frac{F \cdot (1000 \cdot l)^3}{3} \cdot \frac{10^3}{E \cdot I_y} = 79,05 \text{ mm}$$

$$\varphi = \frac{F \cdot (1000 \cdot l)^2}{2} \cdot \frac{10^3}{E \cdot I_y} = 23,71 \cdot 10^{-3}$$

Insert  
Back

Back  
Insert

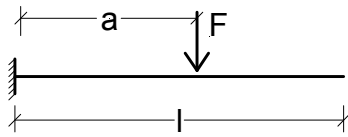

Input values:

Force  $F = 10,00 \text{ kN}$   
 Length  $l = 5,00 \text{ m}$   
 Distance  $a = 2,00 \text{ m}$

Reaction:

$A = F = 10,00 \text{ kN}$

Internal forces:

$M_{\max} = -F \cdot a = -20,00 \text{ kNm}$

Deflection:

$E = 210000,00 \text{ N/mm}^2$   
 $I_y = 25,10 \cdot 10^6 \text{ mm}^4$

$$f = \frac{F \cdot (1000 \cdot a)^3}{3} \cdot \left( l - \frac{a}{3} \right) \cdot \frac{10^3}{E \cdot I_y} = 21,92 \text{ mm}$$

$$\varphi = \frac{F \cdot (1000 \cdot a)^2}{2} \cdot \frac{10^3}{E \cdot I_y} = 3,79 \cdot 10^{-3}$$

Insert  
Back

Back  
Insert

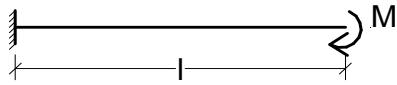

Input values:

Length  $l =$  5,00 m  
Moment  $M =$  10,00 kNm

Reaction:

$A =$  0,00 kN

Internal forces:

$M_{\max} = -M =$  -10,00 kNm

Deflection:

$E =$  210000,00 N/mm<sup>2</sup>  
 $I_y =$  25,10\*10<sup>6</sup> mm<sup>4</sup>

$$f = \frac{M \cdot (1000 \cdot l)^2}{2} \cdot \frac{10^6}{E \cdot I_y} = 23,71 \text{ mm}$$

$$\varphi = \frac{M \cdot (1000 \cdot l)}{2} \cdot \frac{10^6}{E \cdot I_y} = 4,74 \cdot 10^{-3}$$

Insert  
Back

## Templates structural formulae

Section properties

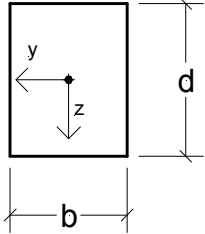
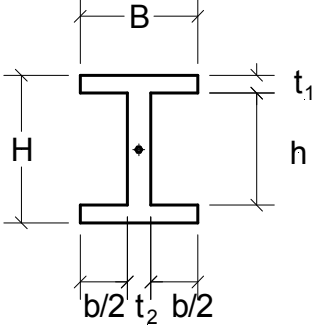
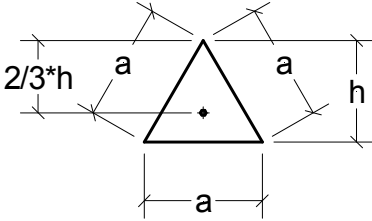
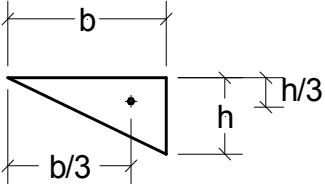
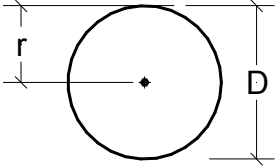
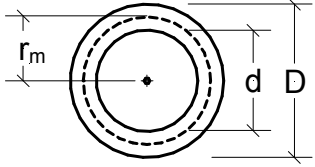
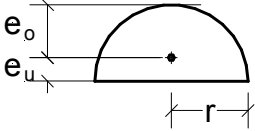
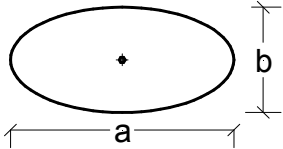
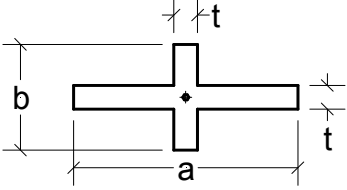
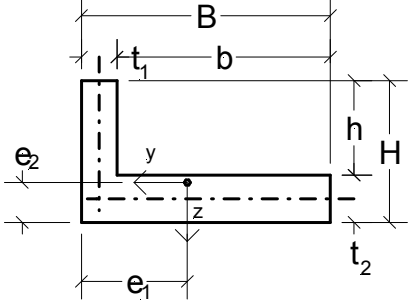
	
<p>Load</p>	<p>Load</p>
	
<p>Load</p>	<p>Load</p>
	
<p>Load</p>	<p>Load</p>
	
<p>Load</p>	<p>Load</p>
	
<p>Load</p>	<p>Load</p>

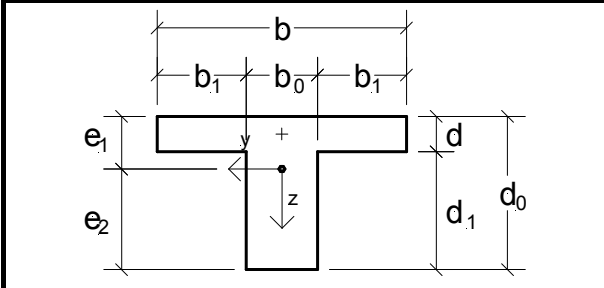

Load

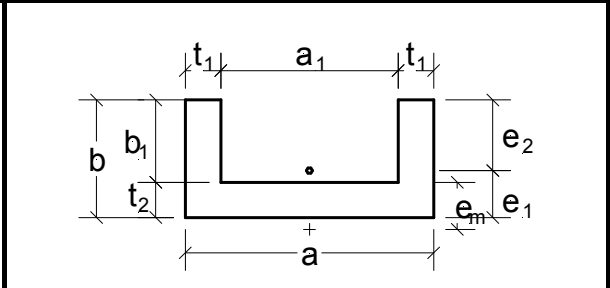

Load



Back  
Insert

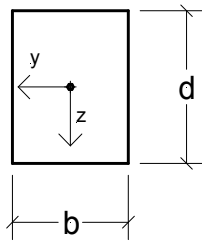

Input values:

Width  $b =$  20,00 cm

Height  $d =$  30,00 cm

$$\text{Area } A = b \cdot d = 600,00 \text{ cm}^2$$

Moment of inertia:

$$I_y = \frac{b \cdot d^3}{12} = 45000,00 \text{ cm}^4$$

Moment of inertia:

$$I_z = \frac{d \cdot b^3}{12} = 20000,00 \text{ cm}^4$$

Section modulus:

$$W_y = \frac{b \cdot d^2}{6} = 3000,00 \text{ cm}^3$$

Section modulus:

$$W_z = \frac{d \cdot b^2}{6} = 2000,00 \text{ cm}^3$$

Torsion area of moment:

$$I_T = \frac{d \cdot b^3}{3} \cdot \left( 1 - 0,630 \cdot \frac{b}{d} + 0,052 \cdot \frac{b^5}{d^5} \right) = 46947,82 \text{ cm}^4$$

Moment of resistance against torsion:

$$W_T = \frac{d \cdot b^3}{31} \cdot \left( 1 - 0,630 \cdot \frac{b}{d} + 0,250 \cdot \frac{b^2}{d^2} \right) = 5350,54 \text{ cm}^3$$

Insert  
Back

Back  
Insert

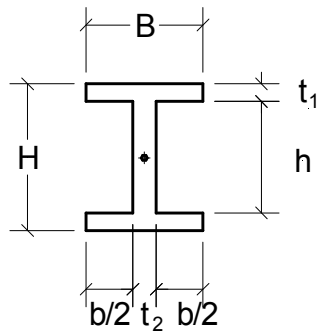

Input values:

Width B = 20,00 cm  
 Height H = 30,00 cm  
 Flange thickness t<sub>1</sub> = 2,00 cm  
 Thickness of web t<sub>2</sub> = 1,50 cm

$$h = H - 2 * t_1 = 26,00 \text{ cm}$$

$$b = B - t_2 = 18,50 \text{ cm}$$

$$\text{Area } A = B * H - (B - t_2) * (H - 2 * t_1) = 119,00 \text{ cm}^2$$

Moment of inertia:

$$I_y = \frac{B * H^3 - b * h^3}{12} = 17903,67 \text{ cm}^4$$

Moment of inertia:

$$I_z = \frac{h * t_2^3 + 2 * t_1 * B^3}{12} = 2673,98 \text{ cm}^4$$

Section modulus:

$$W_y = \frac{2 * I_y}{H} = 1193,58 \text{ cm}^3$$

Section modulus:

$$W_z = \frac{2 * I_z}{B} = 267,40 \text{ cm}^3$$

Torsion area of moment:

$$I_T = \frac{1}{3} * (2 * B * t_1^3 + h * t_2^3) = 135,92 \text{ cm}^4$$

Moment of resistance against torsion:

$$W_T = I_T / \text{MAX}(t_1; t_2) = 67,96 \text{ cm}^3$$

Insert  
Back

Back  
Insert

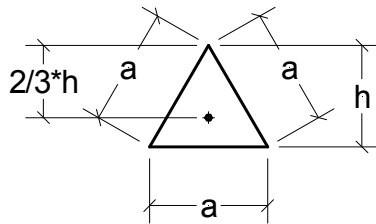

Input values:

$$a = 20,00 \text{ cm}$$

$$h = a \cdot \sqrt{3} = 34,64 \text{ cm}$$

$$\text{Area } A = \frac{a \cdot h}{2} = 346,40 \text{ cm}^2$$

Moment of inertia:

$$I_y = \frac{a \cdot h^3}{36} = 23091,98 \text{ cm}^4$$

Moment of inertia:

$$I_z = \frac{h \cdot a^3}{48} = 5773,33 \text{ cm}^4$$

Section modulus:

$$W_{y,o} = \frac{a \cdot h^2}{24} = 999,94 \text{ cm}^3$$

$$W_{y,u} = \frac{a \cdot h^2}{12} = 1999,88 \text{ cm}^3$$

Section modulus:

$$W_z = \frac{h \cdot a^2}{24} = 577,33 \text{ cm}^3$$

Torsion area of moment:

$$I_T = \frac{h^4}{26} = 55378,12 \text{ cm}^4$$

Moment of resistance against torsion:

$$W_T = \frac{h^3}{13} = 3197,35 \text{ cm}^3$$

Insert  
Back

Back  
Insert

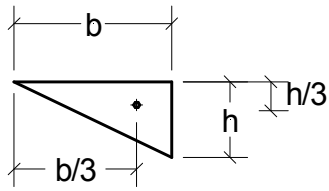

Input values:

$$b = 30,00 \text{ cm}$$

$$h = 20,00 \text{ cm}$$

$$\text{Area } A = \frac{b \cdot h}{2} = 300,00 \text{ cm}^2$$

Moment of inertia:

$$I_y = \frac{b \cdot h^3}{36} = 6666,67 \text{ cm}^4$$

Moment of inertia:

$$I_z = \frac{h \cdot b^3}{36} = 15000,00 \text{ cm}^4$$

Surface centrifugal torque:

$$I_{yz} = \frac{-h^2 \cdot b^2}{72} = 5000,00 \text{ cm}^4$$

Insert  
Back

Back  
Insert

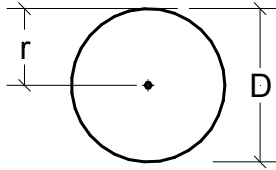

Input values:

$$r = 15,00 \text{ cm}$$

$$D = 2 * r = 30,00 \text{ cm}$$

$$\text{Area } A = \pi * r^2 = 706,86 \text{ cm}^2$$

Moment of inertia:

$$I_y = \frac{\pi * r^4}{4} = 39760,75 \text{ cm}^4$$

Moment of inertia:

$$I_z = \frac{\pi * r^4}{4} = 39760,75 \text{ cm}^4$$

Section modulus:

$$W_y = \frac{\pi * r^3}{4} = 2650,72 \text{ cm}^3$$

Section modulus:

$$W_z = \frac{\pi * r^3}{4} = 2650,72 \text{ cm}^3$$

Torsion area of moment:

$$I_T = \frac{\pi * D^4}{32} = 79521,50 \text{ cm}^4$$

Moment of resistance against torsion:

$$W_T = \frac{\pi * D^3}{16} = 5301,43 \text{ cm}^3$$

Insert  
Back

Back  
Insert

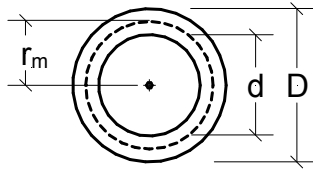

Input values:

$$D = 25,00 \text{ cm}$$

$$d = 20,00 \text{ cm}$$

$$r_m = \frac{D-d}{2} + \frac{d}{2} = 12,50 \text{ cm}$$

$$\text{Area } A = \frac{\pi}{4} * (D^2 - d^2) = 176,71 \text{ cm}^2$$

Moment of inertia:

$$I_y = \frac{\pi}{64} * (D^4 - d^4) = 11320,77 \text{ cm}^4$$

Moment of inertia:

$$I_z = \frac{\pi}{64} * (D^4 - d^4) = 11320,77 \text{ cm}^4$$

Section modulus:

$$W_y = \frac{\pi}{32} * \frac{(D^4 - d^4)}{D} = 905,66 \text{ cm}^3$$

Section modulus:

$$W_z = \frac{\pi}{32} * \frac{(D^4 - d^4)}{D} = 905,66 \text{ cm}^3$$

Torsion area of moment:

$$I_T = \pi * r_m^4 * (D-d) = 383494,87 \text{ cm}^4$$

Moment of resistance against torsion:

$$W_T = \pi * r_m^3 * (D-d) = 30679,59 \text{ cm}^3$$

Insert  
Back

Back  
Insert

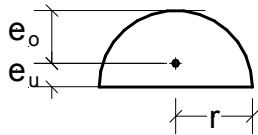

Input values:

$$r = 15,00 \text{ cm}$$

$$e_u = \frac{4}{3} \cdot \frac{r}{\pi} = 6,37 \text{ cm}$$

$$e_o = r - e_u = 8,63 \text{ cm}$$

$$\text{Area } A = \frac{\pi}{2} \cdot r^2 = 353,43 \text{ cm}^2$$

Moment of inertia:

$$I_y = \left( \frac{\pi}{8} - \frac{8}{9 \cdot \pi} \right) \cdot r^4 = 5556,42 \text{ cm}^4$$

Moment of inertia:

$$I_z = \frac{\pi}{8} \cdot r^4 = 19880,37 \text{ cm}^4$$

Section modulus:

$$W_{y,o} = 0,191 \cdot r^3 = 644,63 \text{ cm}^3$$

$$W_{y,u} = 0,259 \cdot r^3 = 874,13 \text{ cm}^3$$

Section modulus:

$$W_z = \frac{\pi}{8} \cdot r^3 = 1325,36 \text{ cm}^3$$

Insert  
Back

Back  
Insert

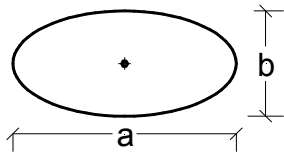

Input values:

$$a = 30,00 \text{ cm}$$

$$b = 15,00 \text{ cm}$$

$$\text{Area } A = \frac{\pi}{4} * a * b = 353,43 \text{ cm}^2$$

Moment of inertia:

$$I_y = \frac{\pi}{64} * a * b^3 = 4970,09 \text{ cm}^4$$

Moment of inertia:

$$I_z = \frac{\pi}{64} * a^3 * b = 19880,37 \text{ cm}^4$$

Section modulus:

$$W_y = \frac{\pi}{32} * a * b^2 = 662,68 \text{ cm}^3$$

Section modulus:

$$W_z = \frac{\pi}{32} * a^2 * b = 1325,36 \text{ cm}^3$$

Torsion area of moment:

$$I_T = \frac{\pi}{16} * \frac{a^3 * b^3}{a^2 + b^2} = 15904,30 \text{ cm}^4$$

Moment of resistance against torsion:

$$W_T = \frac{\pi}{16} * a * b^2 = 1325,36 \text{ cm}^3$$

Insert  
Back



Back  
Insert

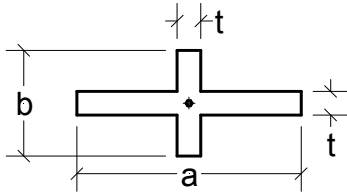

Input values:

a = 30,00 cm  
b = 15,00 cm  
t = 2,50 cm

$$\text{Area } A = t * (a + b - t) = 106,25 \text{ cm}^2$$

Moment of inertia:

$$I_y = \frac{t * b^3 + (a - t) * t^3}{12} = 738,93 \text{ cm}^4$$

Moment of inertia:

$$I_z = \frac{t * a^3 + (b - t) * t^3}{12} = 5641,28 \text{ cm}^4$$

Section modulus:

$$W_y = \frac{2 * I_y}{b} = 98,52 \text{ cm}^3$$

Section modulus:

$$W_z = \frac{2 * I_z}{a} = 376,09 \text{ cm}^3$$

Torsion area of moment:

$$I_T = \frac{t^3}{3} * (a + b - 0,15 * t) = 232,42 \text{ cm}^4$$

Moment of resistance against torsion:

$$W_T = \frac{I_T}{t} = 92,97 \text{ cm}^3$$

Insert  
Back

Back  
Insert

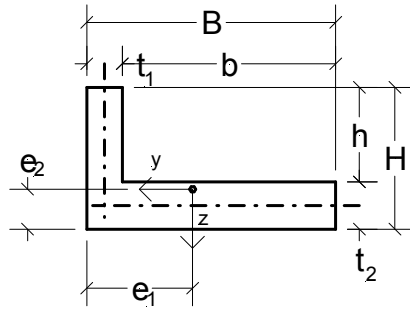

Input values:

B = 30,00 cm  
 H = 15,00 cm  
 t<sub>1</sub> = 2,50 cm  
 t<sub>2</sub> = 3,00 cm

b = B - t<sub>1</sub> = 27,50 cm  
 h = H - t<sub>2</sub> = 12,00 cm  
 Area A = H \* B - h \* b = 120,00 cm<sup>2</sup>  

$$e_1 = \frac{t_2 * B^2 + h * t_1^2}{2 * A} = 11,56 \text{ cm}$$
  

$$e_2 = \frac{t_1 * H^2 + b * t_2^2}{2 * A} = 3,38 \text{ cm}$$

Moment of inertia:

$$I_y = \frac{1}{3} * (t_1 * H^3 + b * t_2^3 - A * e_2^2) = 2603,02 \text{ cm}^4$$

Moment of inertia:

$$I_z = \frac{1}{3} * (h * t_1^3 + t_2 * B^3 - A * e_1^2) = 21717,16 \text{ cm}^4$$

Surface centrifugal torque:

$$I_{yz} = t_1 * H * \left(e_1 - \frac{t_1}{2}\right) * \left(e_2 - \frac{H}{2}\right) + b * t_2 * \left(e_2 - \frac{t_2}{2}\right) * \left(e_1 - t_1 - \frac{b}{2}\right) = -2320,31 \text{ cm}^4$$

Algebraic sign:

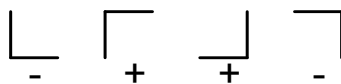

Torsion area of moment:

$$I_T = \frac{1}{3} * (H * t_1^3 + b * t_2^3) = 325,63 \text{ cm}^4$$

Moment of resistance against torsion:

$$W_T = I_T / \text{MAX}(t_1; t_2) = 108,54 \text{ cm}^3$$

Insert  
Back

Back  
Insert

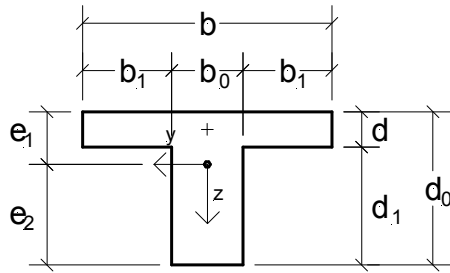

Input values:

$b = 30,00 \text{ cm}$   
 $d = 3,00 \text{ cm}$   
 $b_0 = 3,00 \text{ cm}$   
 $d_0 = 20,00 \text{ cm}$

$d_1 = d_0 - d = 17,00 \text{ cm}$

$b_1 = \frac{b - b_0}{2} = 13,50 \text{ cm}$

$\text{Area } A = b * d + b_0 * d_1 = 141,00 \text{ cm}^2$

$e_1 = \frac{2 * b_1 * d^2 + b_0 * d_0^2}{2 * A} = 5,12 \text{ cm}$

$e_2 = d_0 - e_1 = 14,88 \text{ cm}$

Moment of inertia:

$I_y = \frac{1}{3} * (2 * b_1 * d^3 + b_0 * d_0^3) - A * e_1^2 = 4546,77 \text{ cm}^4$

Moment of inertia:

$I_z = \frac{d * b^3 + d_1 * b_0^3}{12} = 6788,25 \text{ cm}^4$

Section modulus:

$W_{y,o} = \frac{I_y}{e_1} = 888,04 \text{ cm}^3$

$W_{y,u} = \frac{I_y}{e_2} = 305,56 \text{ cm}^3$

Section modulus:

$W_z = \frac{d * b^3 + d_1 * b_0^3}{6 * b} = 452,55 \text{ cm}^3$

Torsional constant for thin-walled cross-sections only:

$I_T = \frac{1}{3} * (b * d^3 + d_1 * b_0^3) = 172,00 \text{ cm}^4$

Moment of resistance against torsion for thin-walled cross-sections only:

$W_T = I_T / \text{MAX}(b_0; d) = 57,33 \text{ cm}^3$

Insert  
Back

Back  
Insert

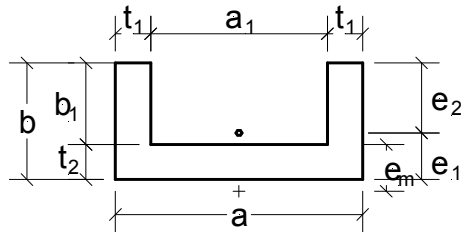

Input values:

$$a = 30,00 \text{ cm}$$

$$b = 20,00 \text{ cm}$$

$$t_1 = 2,00 \text{ cm}$$

$$t_2 = 2,00 \text{ cm}$$

$$b_1 = b - t_1 = 18,00 \text{ cm}$$

$$a_1 = a - 2 * t_1 = 26,00 \text{ cm}^4$$

$$e_1 = \frac{a_1 * t_2^2 + 2 * b^2 * t_1}{2 * a_1 * t_2 + 4 * b * t_1} = 6,45 \text{ cm}$$

$$e_2 = b - e_1 = 13,55 \text{ cm}$$

Thin walled cross section:

$$A_S = (a_1 + t_1) * t_2 = 56,00 \text{ cm}^2$$

$$A_G = \left(b_1 + \frac{t_2}{2}\right) * t_1 = 38,00 \text{ cm}^2$$

$$e_m = \frac{b_1 + \frac{t_2}{2}}{2 + \frac{A_S}{3 * A_G}} + \frac{t_2}{2} = 8,63 \text{ cm}$$

$$\text{Area } A = t_2 * a + 2 * t_1 * b_1 = 132,00 \text{ cm}^2$$

Moment of inertia:

$$I_y = \frac{1}{3} * (a * e_1^3 - a_1 * (e_1 - t_2)^3 + 2 * e_2^3 * t_1) = 5236,73 \text{ cm}^4$$

Moment of inertia:

$$I_z = \frac{b * a^3 - b_1 * a_1^3}{12} = 18636,00 \text{ cm}^4$$

Section modulus:

$$W_{y,o} = \frac{I_y}{e_2} = 386,47 \text{ cm}^3$$

$$W_{y,u} = \frac{I_y}{e_1} = 811,90 \text{ cm}^3$$

Section modulus:

$$W_z = \frac{b \cdot a^3 - b_1 \cdot a_1^3}{6 \cdot a} = 300,00 \text{ cm}^3$$

Torsional constant for thin-walled cross-sections only:

$$I_T = \frac{1}{3} \cdot (2 \cdot b \cdot t_1^3 + a_1 \cdot t_2^3) = 176,00 \text{ cm}^4$$

Moment of resistance against torsion for thin-walled cross-sections only:

$$W_T = I_T / \text{MAX}(t_1; t_2) = 88,00 \text{ cm}^3$$

[Insert](#)  
[Back](#)

## Templates structural formulae

Calculation of Areas

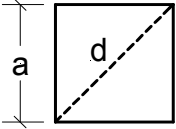
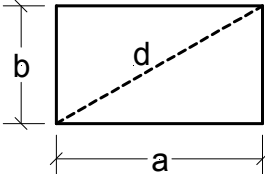
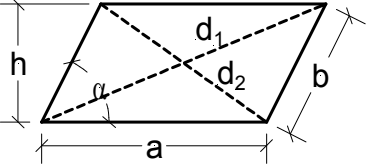
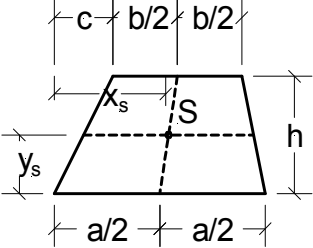
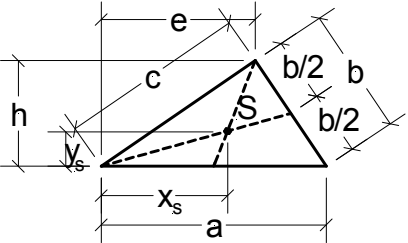
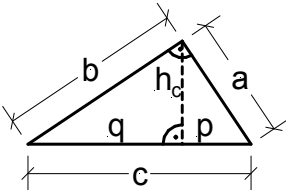
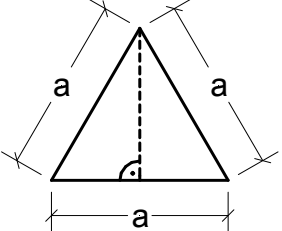
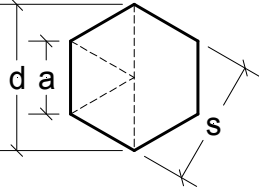
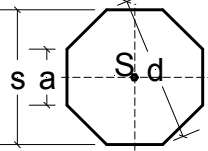
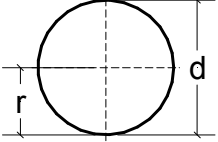
	
<p>Load</p>	<p>Load</p>
	
<p>Load</p>	<p>Load</p>
	
<p>Load</p>	<p>Load</p>
	
<p>Load</p>	<p>Load</p>
	
<p>Load</p>	<p>Load</p>

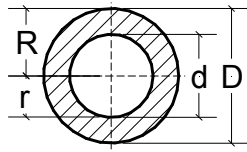

Load

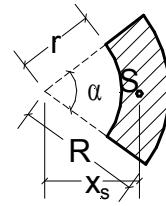

Load

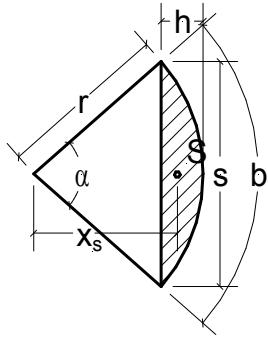

Load

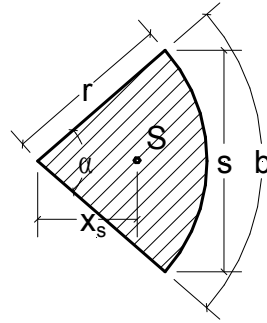

Load

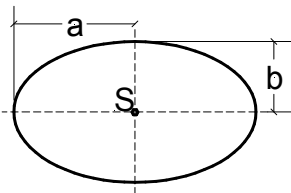

Load

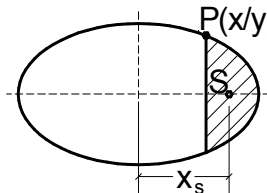

Load



[Back](#)  
[Insert](#)

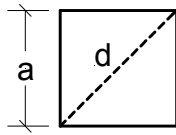

Square:

Edge length  $a =$  20,00 cm

Area  $A = a^2 = 400,00 \text{ cm}^2$

Diagonal  $d = a \cdot \sqrt{2} = 28,28 \text{ cm}$

[Insert](#)  
[Back](#)

Back  
Insert

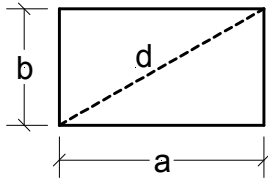

Rectangle:

Edge length a = 20,00 cm

Edge length b = 30,00 cm

Area A =  $a * b$  = 600,00 cm<sup>2</sup>

Diagonal d =  $\sqrt{a^2 + b^2}$  = 36,06 cm

Insert  
Back

Back  
Insert

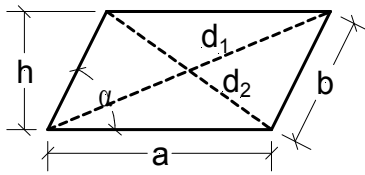

Parallelogram:

Edge length a = 20,00 cm

Edge length b = 30,00 cm

Angle α = 75,00 °

Height h =  $b \cdot \sin(\alpha)$  = 28,98 cm

Area A =  $a \cdot h$  = 579,60 cm<sup>2</sup>

Diagonal d<sub>1</sub> =  $\sqrt{\left(a + h \cdot \frac{1}{\tan(\alpha)}\right)^2 + h^2}$  = 40,13 cm

Diagonal d<sub>2</sub> =  $\sqrt{\left(a - h \cdot \frac{1}{\tan(\alpha)}\right)^2 + h^2}$  = 31,46 cm

Insert  
Back

Back  
Insert

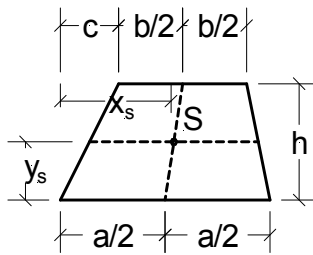

Trapezoid:

Edge length a = 20,00 cm  
 Edge length b = 30,00 cm  
 Height h = 20,00 '  
 Length c = 8,00 cm

$$\text{Area } A = h \cdot \frac{a+b}{2} = 500,00 \text{ cm}^2$$

Distance of the center of gravity:

$$x_s = \frac{1}{3} \cdot \left( a + b + c - b \cdot \frac{a-c}{a+b} \right) = 16,93 \text{ cm}$$

$$y_s = \frac{h}{3} \cdot \frac{a+2 \cdot b}{a+b} = 10,67 \text{ cm}$$

Insert  
Back

Back  
Insert

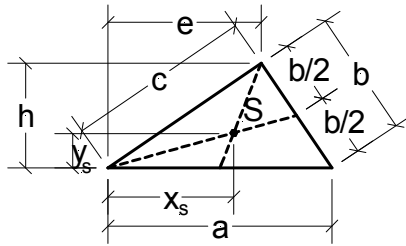

Triangle:

Edge length a = 20,00 cm  
 Height h = 20,00 cm  
 Length e = 20,00 cm

Edge length b =  $\sqrt{(a-e)^2 + h^2}$  = 20,00 cm

Edge length c =  $\sqrt{e^2 + h^2}$  = 28,28 cm

Area A =  $a \cdot \frac{h}{2}$  = 200,00 cm<sup>2</sup>

s =  $\frac{a + b + c}{2}$  = 34,14 cm

Area A =  $\sqrt{s \cdot (s-a) \cdot (s-b) \cdot (s-c)}$  = 200,00 cm<sup>2</sup>

Distance of the center of gravity:

$x_s = \frac{a+e}{3}$  = 13,33 cm

$y_s = \frac{h}{3}$  = 6,67 cm

Insert  
Back

Back  
Insert

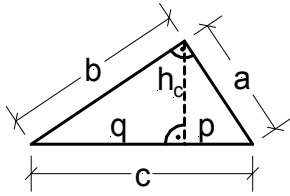

Right angle triangle:

Edge length a =

30,00 cm

Height hc =

20,00 cm

$$\text{Area } A = a \cdot \frac{h_c}{2} = 300,00 \text{ cm}^2$$

Insert  
Back

Back  
Insert

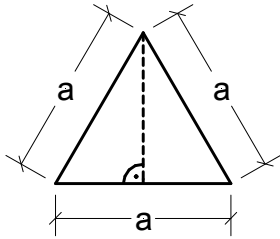

Equilateral triangle:

Edge length a =

30,00 cm

$$\begin{aligned} \text{Area } A &= 0,25 * a^2 * \sqrt{3} &= & 389,71 \text{ cm}^2 \\ \text{Height } h &= 0,5 * a * \sqrt{3} &= & 25,98 \text{ cm} \\ \text{Perimeter } U &= 3 * a &= & 90,00 \text{ cm} \end{aligned}$$

Insert  
Back

Back  
Insert

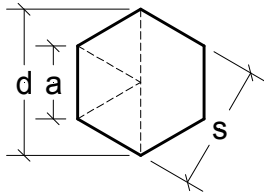

Regular hexagon:  
Edge length a =

20,00 cm

Area A =	$1,5 \cdot a^2 \cdot \sqrt{3}$	=	1039,23 cm <sup>2</sup>
Diameter d =	$2 \cdot a$	=	40,00 cm
Distance s =	$0,5 \cdot d \cdot \sqrt{3}$	=	34,64 cm

Insert  
Back



Back  
Insert

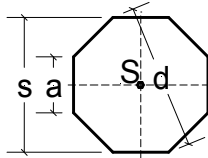

Regular octagon:

Edge length  $a = 20,00 \text{ cm}$

Distance  $s = a \cdot \sqrt{2} + a = 48,28 \text{ cm}$

Area  $A = \frac{2 \cdot a \cdot s}{s} = 1931,20 \text{ cm}^2$

Diameter  $d = \frac{s}{\cos(22,5)} = 52,26 \text{ cm}$

Insert  
Back

[Back](#)  
[Insert](#)

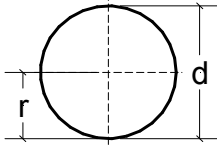

Circle:

Radius  $r =$  20,00 cm

Diameter  $d =$   $2 * r$  = 40,00 cm

Area  $A =$   $\pi * r^2$  = 1256,64 cm<sup>2</sup>

Perimeter  $U =$   $2 * \pi * r$  = 125,66 cm

[Insert](#)  
[Back](#)

Back  
Insert

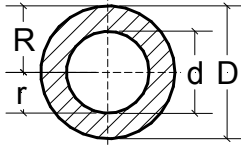

Circular ring:

Radius  $r =$  15,00 cm

Radius  $R =$  20,00 cm

Diameter  $d =$   $2 * r$  = 30,00 cm

Diameter  $D =$   $2 * R$  = 40,00 cm

Area  $A =$   $\pi * \frac{D^2 - d^2}{4}$  = 549,78 '

Insert  
Back

Back  
Insert

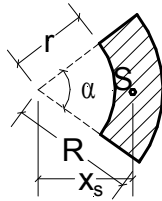

Circular ring:

Radius  $r =$  15,00 cm

Radius  $R =$  20,00 cm

Angle  $\alpha =$  70,00 °

$$\text{Area } A = \pi \cdot \alpha \cdot \frac{R^2 - r^2}{360} = 106,90 \text{ cm}^2$$

Distance of the center of gravity:

$$x_s = \frac{240}{\pi} \cdot \frac{R^3 - r^3}{R^2 - r^2} \cdot \frac{\sin\left(\frac{\alpha}{2}\right)}{\alpha} = 16,54 \text{ cm}$$

Insert  
Back

Back  
Insert

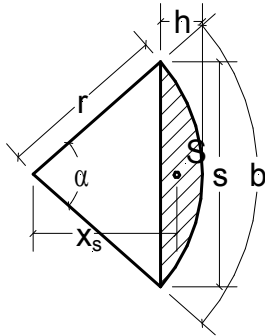

Section of a circle:

Radius  $r = 15,00 \text{ cm}$   
 Angle  $\alpha = 70,00^\circ$

$$\text{Length } b = \frac{\pi * r * \alpha}{180} = 18,33 \text{ cm}$$

$$\text{Length } s = 2 * r * \sin\left(\frac{\alpha}{2}\right) = 17,21 \text{ cm}$$

$$\text{Width } h = 0,5 * s * \tan\left(\frac{\alpha}{2}\right) = 6,03 \text{ cm}$$

$$\text{Area } A = 0,5 * r^2 * \left(\pi * \frac{\alpha}{180} - \sin(\alpha)\right) = 31,73 \text{ cm}^2$$

Distance of the center of gravity:

$$x_s = \frac{s^3}{12 * A} = 13,39 \text{ cm}$$

Insert  
Back

Back  
Insert

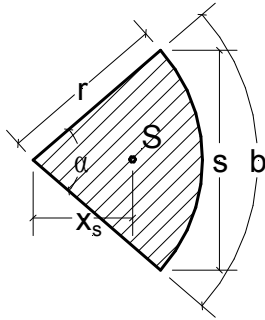

Sector of a circle:

Radius  $r = 15,00 \text{ cm}$   
 Angle  $\alpha = 70,00^\circ$

Length  $b = \pi * r * \frac{\alpha}{180} = 18,33 \text{ cm}$

Length  $s = 2 * r * \sin\left(\frac{\alpha}{2}\right) = 17,21 \text{ cm}$

Area  $A = b * \frac{r}{2} = 137,47 \text{ cm}^2$

Distance of the center of gravity:

$x_s = \frac{2 * r * s}{3 * b} = 9,39 \text{ cm}$

Insert  
Back

Back  
Insert

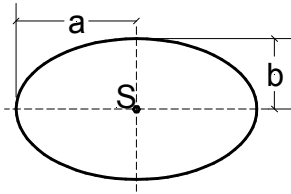

Ellipse:

Length a = 15,00 cm

Length b = 10,00 cm

Area A =  $\pi * a * b$  = 471,24 cm<sup>2</sup>

$\lambda = \frac{a - b}{a + b}$  = 0,20

Insert  
Back

Back  
Insert

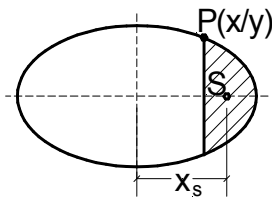

Section of an ellipse:

Length a = 15,00 cm

Length b = 10,00 cm

Distance x = 10,00 cm

$$y = \frac{b}{a} \cdot \sqrt{a^2 - x^2} = 7,45 \text{ cm}$$

$$\lambda = \frac{a - b}{a + b} = 0,20$$

$$\text{Area A} = \frac{b}{a} \cdot \left( \left( \frac{1}{2} \cdot \pi - \frac{1}{\sin\left(\frac{x}{a}\right)} \right) \cdot a^2 - x \cdot \sqrt{a^2 - x^2} \right) = -12730,76 \text{ cm}^2$$

Insert  
Back



## Templates structural formulae

Volume

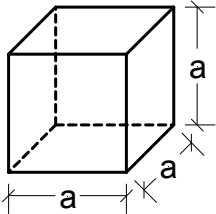
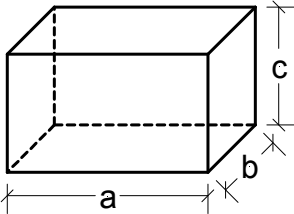
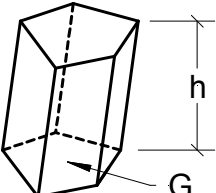
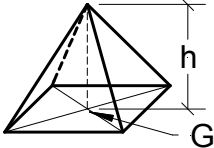
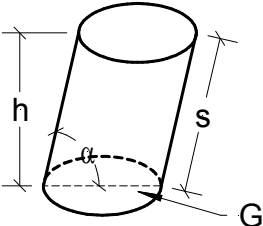
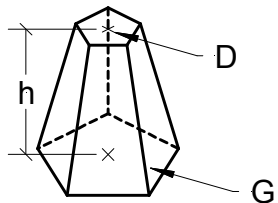
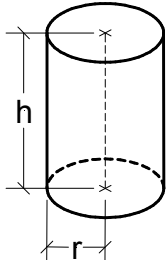
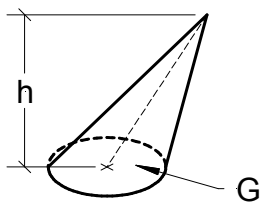
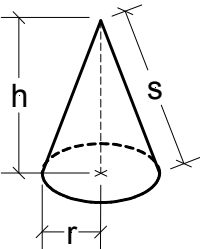
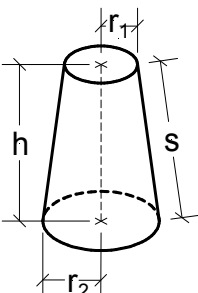
	
<p>Load</p>	<p>Load</p>
	
<p>Load</p>	<p>Load</p>
	
<p>Load</p>	<p>Load</p>
	
<p>Load</p>	<p>Load</p>
	
<p>Load</p>	<p>Load</p>

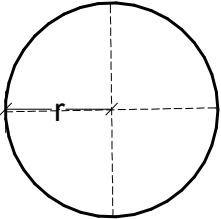
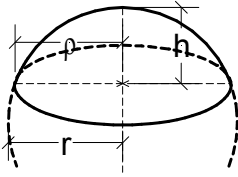
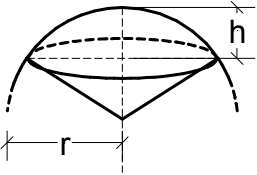
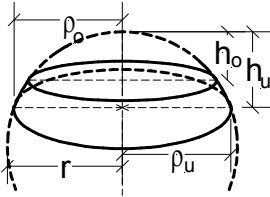
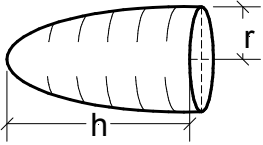
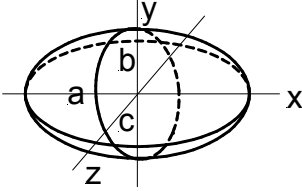
	
<p>Load</p>	<p>Load</p>
	
<p>Load</p>	<p>Load</p>
	
<p>Load</p>	<p>Load</p>

Back  
Insert

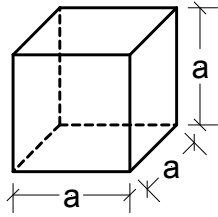

Cube:

Edge length  $a =$

20,00 cm

Volume  $V =$

$a^3$

$=$

8000,00 cm<sup>3</sup>

Insert  
Back

[Back](#)  
[Insert](#)

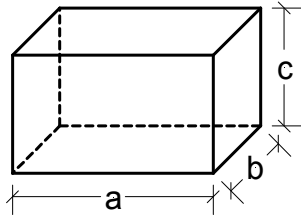

Cuboid:

Edge length a = 20,00 cm

Edge length b = 12,00 cm

Edge length c = 15,00 cm

$$\text{Volume } V = a * b * c = 3600,00 \text{ cm}^3$$

[Insert](#)  
[Back](#)

[Back](#)  
[Insert](#)

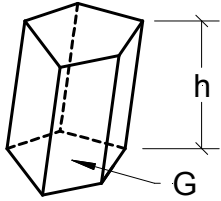

Prism:

Base area  $G =$

220,00 cm<sup>2</sup>

Height  $h =$

20,00 cm

Volume  $V =$

$G \cdot h$

$=$

4400,00 cm<sup>3</sup>

[Insert](#)  
[Back](#)

Back  
Insert

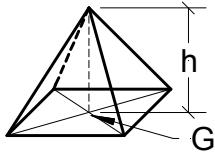

Pyramid:

Base area  $G =$

220,00 cm<sup>2</sup>

Height  $h =$

20,00 cm

Volume  $V =$

$$\frac{1}{3} * G * h$$

=

1466,67 cm<sup>3</sup>

Insert  
Back

Back  
Insert

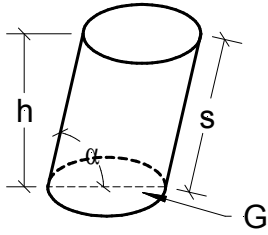

Cylinder:

Radius  $r = 8,00 \text{ cm}$

Height  $h = 20,00 \text{ cm}$

Angle  $\alpha = 70,00^\circ$

Base area  $G = \pi * r^2 = 201,06 \text{ cm}^2$

Volume  $V = G * h = 4021,20 \text{ cm}^3$

Generator  $s = \frac{h}{\sin(\alpha)} = 21,28 \text{ cm}$

Generator surface  $M = s * 2 * \pi * r = 1069,65 \text{ cm}^2$

Insert  
Back



Back  
Insert

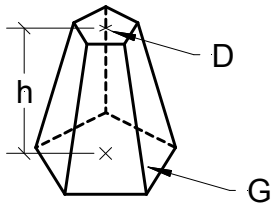

Frustum of pyramid:

Height  $h = 20,00 \text{ cm}$

Base area  $G = 220,00 \text{ cm}^2$

Top area  $D = 85,00 \text{ cm}^2$

Volume  $V = \frac{h}{3} * (G + \sqrt{G * D} + D) = 2944,99 \text{ cm}^3$

Insert  
Back

[Back](#)  
[Insert](#)

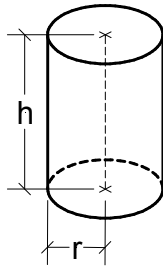

right Cylinder:

Radius  $r = 8,00$  cm  
Height  $h = 20,00$  cm

Base area $G =$	$\pi * r^2$	=	201,06 cm <sup>2</sup>
Volume $V =$	$G * h$	=	4021,20 cm <sup>3</sup>
Generator surface $M =$	$h * 2 * \pi * r$	=	1005,31 cm

[Insert](#)  
[Back](#)

Back  
Insert

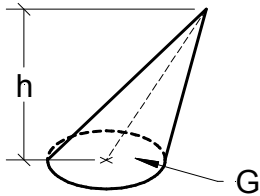

Cone:

Radius  $r = 8,00$  cm

Height  $h = 20,00$  cm

Base area  $G = \pi * r^2 = 201,06$  cm<sup>2</sup>

Volume  $V = \frac{1}{3} * G * h = 1340,40$  cm<sup>3</sup>

Insert  
Back

Back  
Insert

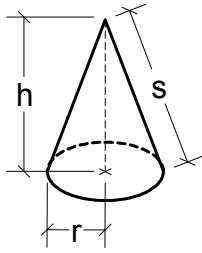

right circular cone:

Radius  $r = 8,00$  cm  
Height  $h = 20,00$  cm

$$\begin{aligned} \text{Base area } G &= \pi * r^2 &= & 201,06 \text{ cm}^2 \\ \text{Volume } V &= \frac{1}{3} * G * h &= & 1340,40 \text{ cm}^3 \\ \text{Generator } s &= \sqrt{r^2 + h^2} &= & 21,54 \text{ cm} \\ \text{Generated surface } M &= s * \pi * r &= & 541,36 \text{ cm}^2 \end{aligned}$$

Insert  
Back

Back  
Insert

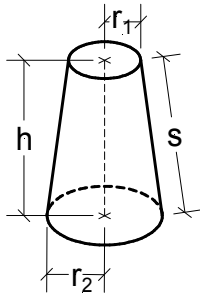

Truncated circular cone:

Radius  $r_2 =$  10,00 cm  
 Radius  $r_1 =$  5,00 cm  
 Height  $h =$  20,00 cm

$$\begin{aligned} \text{Base area } G &= \pi * r_2^2 &= & 314,16 \text{ cm}^2 \\ \text{Top area } D &= \pi * r_1^2 &= & 78,54 \text{ cm}^2 \\ \text{Volume } V &= \frac{h}{3} * (G + \sqrt{G * D} + D) &= & 3665,20 \text{ cm}^3 \\ \text{Volume } V &= \frac{1}{3} * \pi * h * (r_1^2 + r_1 * r_2 + r_2^2) &= & 3665,19 \text{ cm}^3 \end{aligned}$$

Insert  
Back

[Back](#)  
[Insert](#)

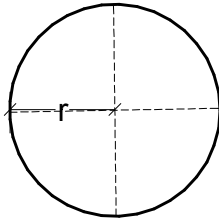

Ball:

Radius  $r =$  10,00 cm

$$\text{Volume } V = \frac{4}{3} \pi r^3 = 4188,79 \text{ cm}^3$$

$$\text{Surface } O = 4 \pi r^2 = 1256,64 \text{ cm}^2$$

[Insert](#)  
[Back](#)

Back  
Insert

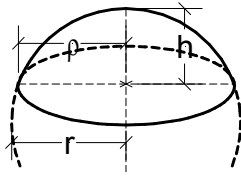

Spherical segment:

Radius  $r =$  10,00 cm  
Height  $h =$  7,00 cm

Volume $V =$	$\frac{1}{3} \cdot \pi \cdot h^2 \cdot (3 \cdot r - h)$	=	1180,19 cm <sup>3</sup>
Generator surface $M =$	$2 \cdot \pi \cdot r \cdot h$	=	439,82 cm <sup>2</sup>
Surface $O =$	$\pi \cdot h \cdot (4 \cdot r - h)$	=	725,71 cm <sup>2</sup>
Radius $\rho =$	$\sqrt{h \cdot (2 \cdot r - h)}$	=	9,54 cm

Insert  
Back

Back  
Insert

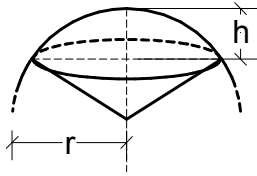

Spherical sector:

Radius  $r =$  10,00 cm

Height  $h =$  7,00 cm

$$\text{Volume } V = \frac{2}{3} \pi r^2 h = 1466,08 \text{ cm}^3$$

$$\text{Surface } O = \pi r (2h + \sqrt{h(2+r-h)}) = 625,68 \text{ cm}^2$$

Insert  
Back



Back  
Insert

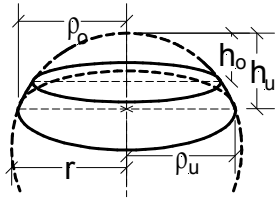

Spherical layer:

Radius  $r = 10,00 \text{ cm}$

Height  $h_0 = 3,00 \text{ cm}$

Height  $h_u = 7,00 \text{ cm}$

Radius  $\rho_0 = \sqrt{h_0 \cdot (2 \cdot r - h_0)} = 7,14 \text{ cm}$

Radius  $\rho_u = \sqrt{h_u \cdot (2 \cdot r - h_u)} = 9,54 \text{ cm}$

Volume  $V = \frac{1}{6} \cdot \pi \cdot (h_u - h_0) \cdot (3 \cdot \rho_u^2 + 3 \cdot \rho_0^2 + (h_u - h_0)^2) = 925,67 \text{ cm}^3$

Surface  $A = 2 \cdot \pi \cdot r \cdot (h_u - h_0) = 251,33 \text{ cm}^2$

Insert  
Back

[Back](#)  
[Insert](#)

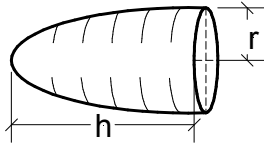

Paraboloid of revolution:

Radius  $r =$  10,00 cm  
Height  $h =$  12,00 cm

$$\text{Volume } V = \frac{1}{2} * \pi * r^2 * h = 1884,95 \text{ cm}^3$$

[Insert](#)  
[Back](#)

[Back](#)  
[Insert](#)

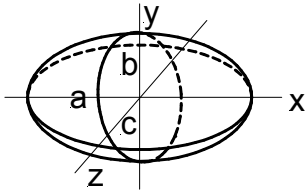

Ellipsoid:

Semixis length a =

15,00 cm

Semixis length b =

10,00 cm

Semixis length c =

8,00 cm

$$\text{Volume } V = \frac{4}{3} \pi a b c = 5026,54 \text{ cm}^3$$

[Insert](#)  
[Back](#)